

System for debris removal and cutting
WANGEN X-UNIT

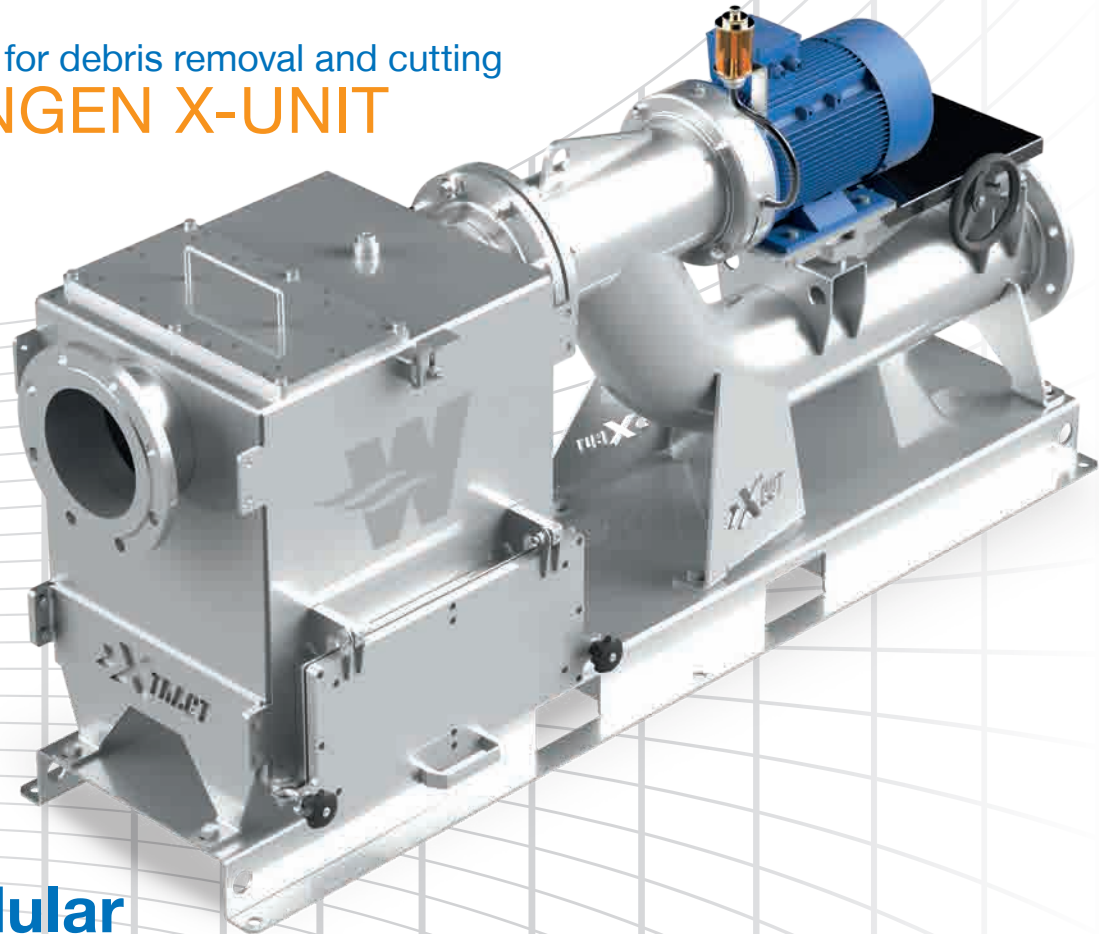

The
modular
system for reliable protection
of plant equipment:

X-TRACT
+ X-CUT
= X-UNIT.

WANGEN X-UNIT

Complete system for debris removal and cutting

The WANGEN X-UNIT is employed in every case where foreign bodies and debris from pumped media must be separated out and cutted:

- Biogas plants
- Biowaste utilisation
- Stable application in agricultural technology
- Liquid manure technology vehicle construction
- Municipal waste water treatment plants

Modular structure

The WANGEN X-UNIT consists of the two modules X-TRACT and X-CUT. Both components are available separately and are optimally co-ordinated with each other as an X-UNIT.

Increased process safety

through removal of system-harmful foreign bodies and debris with the aid of the foreign body separator X-TRACT and the cutting unit X-CUT. Optimum adaptation of the cutting unit to the medium easily possible.

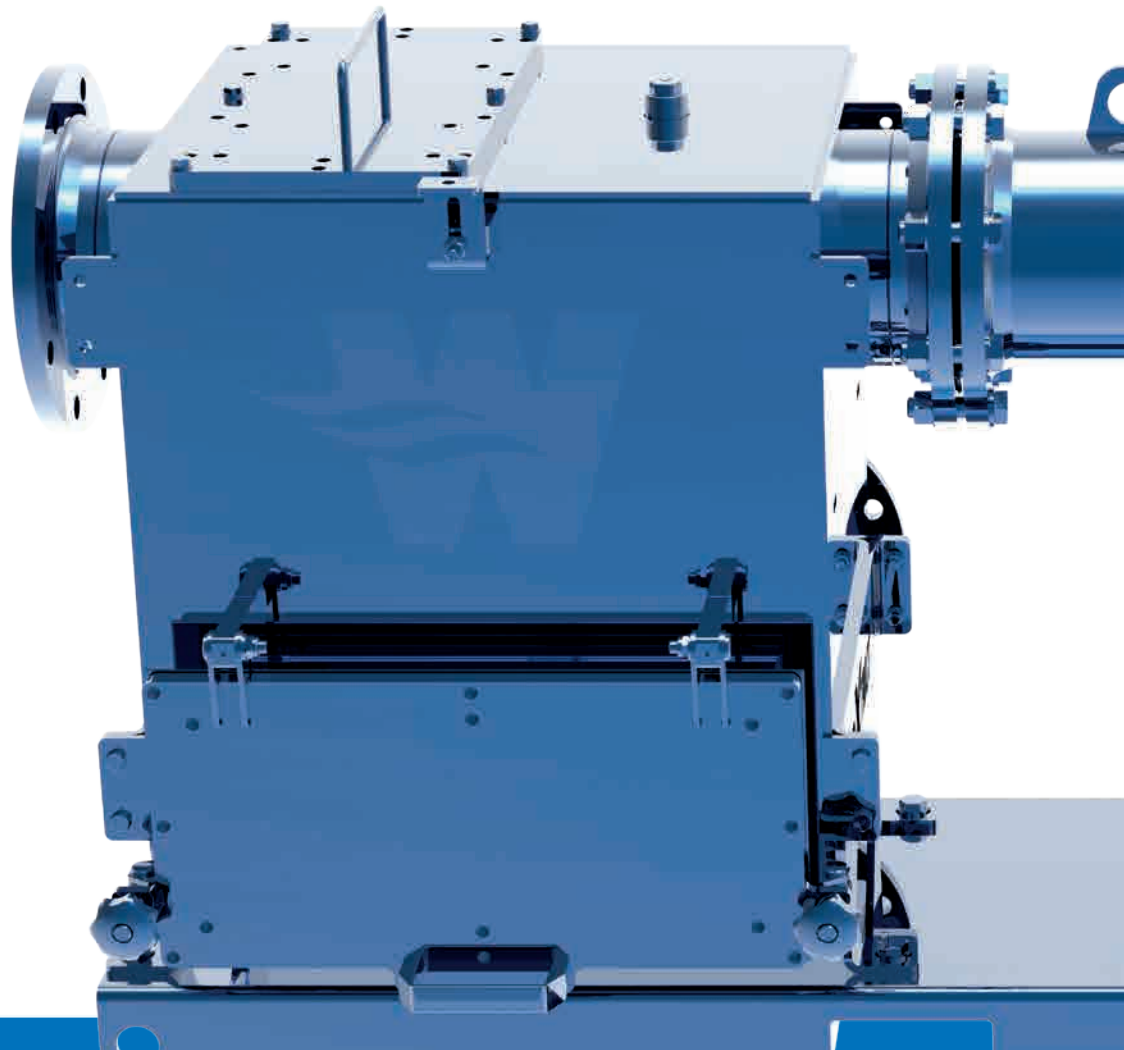

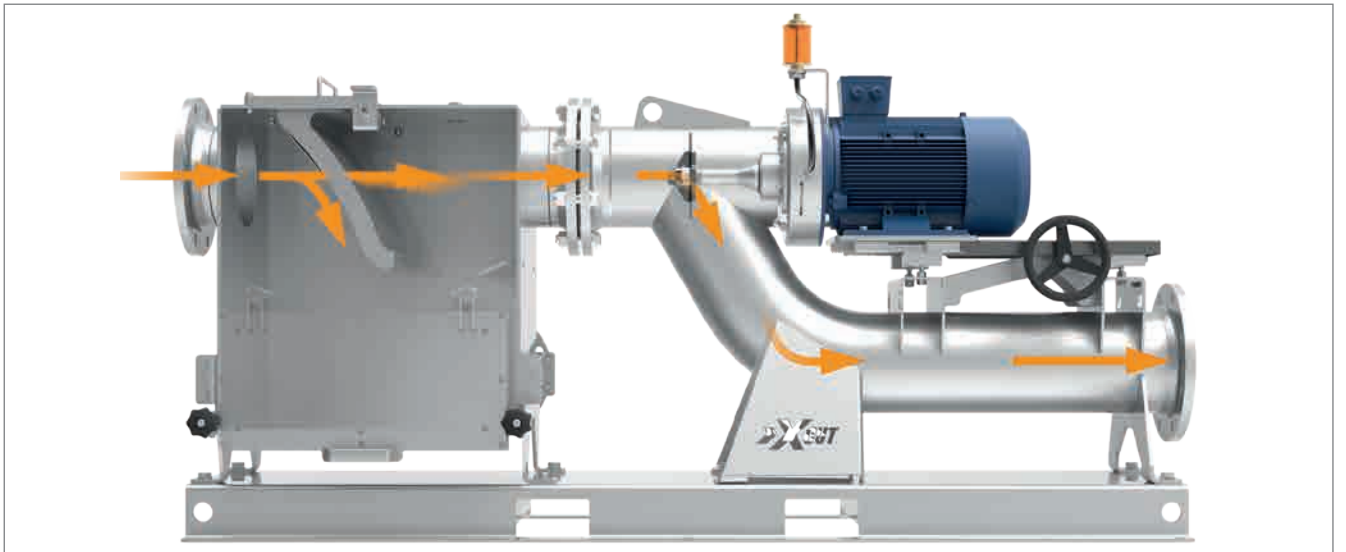
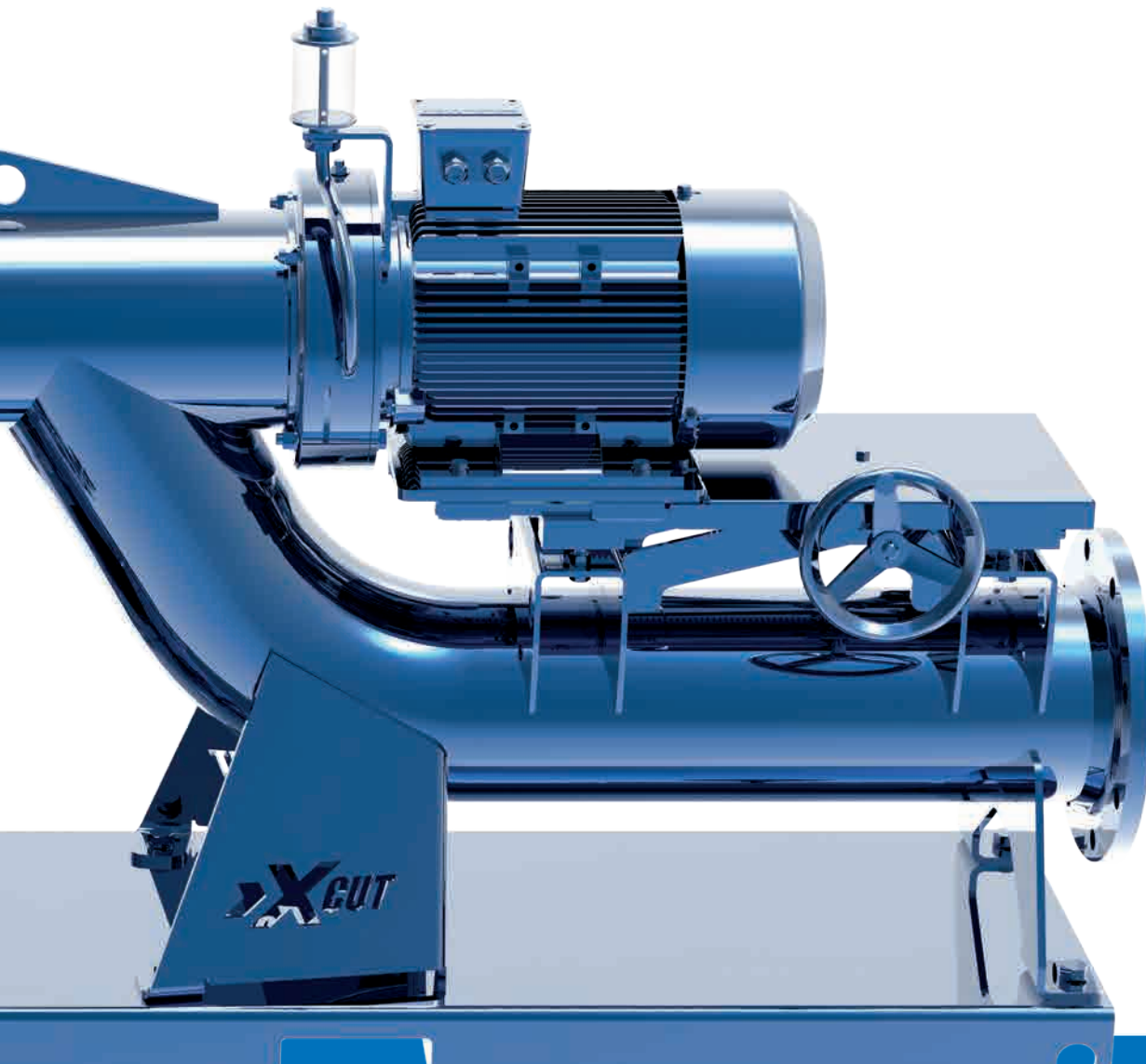

Illustration of the directions of flow of the medium through the X-UNIT



WANGEN X-TRACT

Process-optimized adaptation

to the pumped media by a simple change of the screen geometry.

Easy removal of the foreign bodies

through large openings.

Problem-free integration into existing systems

through standard flange and compact, space-efficient construction design. The modular structure enables installation in case of confined space conditions through separate installation.

Further plus points:

- Very rugged implementation.
- Flow-optimized catch container.
- Foreign body removal through wheelbarrow possible with mounting stand.
- Additional rinse connections available.

The WANGEN X-TRACT is a module for the separation of foreign bodies from the pumped medium, for the protection of systems and pumps. Especially in biogas plants and in agricultural technology, stones, wood, metal parts or other foreign bodies are taken out of the pumped medium, in order to ensure a troublefree and wear reduced operation of the system.

Supply materials with a higher density than water (such as stones) sink down through force of gravity and are routed by the screen and the container geometry to the removal opening. Therefore no movable component parts are necessary for the separation of such foreign bodies. The geometry of the screen guarantees continuous cleaning through the inflowing pumped medium. The X-TRACT thus avoids faults and associated down times of the entire system.

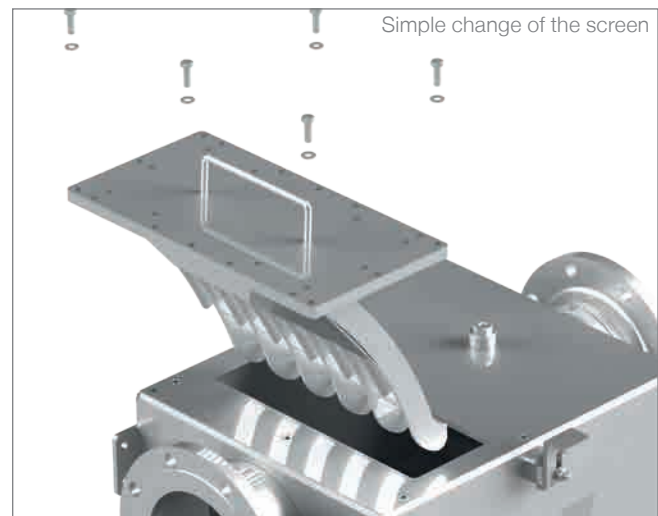
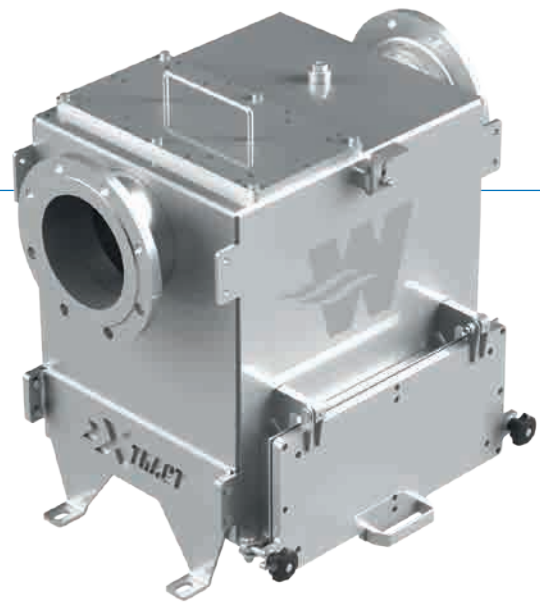

X-TRACT design components:

- 1 Media inlet: Pipe connections optional DN200 / PN10
- 2 Connection for sensor to provide optimal monitoring and control
- 3 Debris catchment area
- 4 Various screen for the removal of debris and heavy objects
- 5 Flange DN150 / PN10 for the emptying / flushing the catchment area
- 6 Large opening for the removal of settled foreign bodies
- 7 Discharge: pipe connections DN200 / PN10

Material: Galvanized mild steel (further materials on request).

Maximum capacity: 330.004 gph (1,250 m³/h / 347 l/sec).

Maximum pressure: 87 psi (6 bar), preferred on suction side.

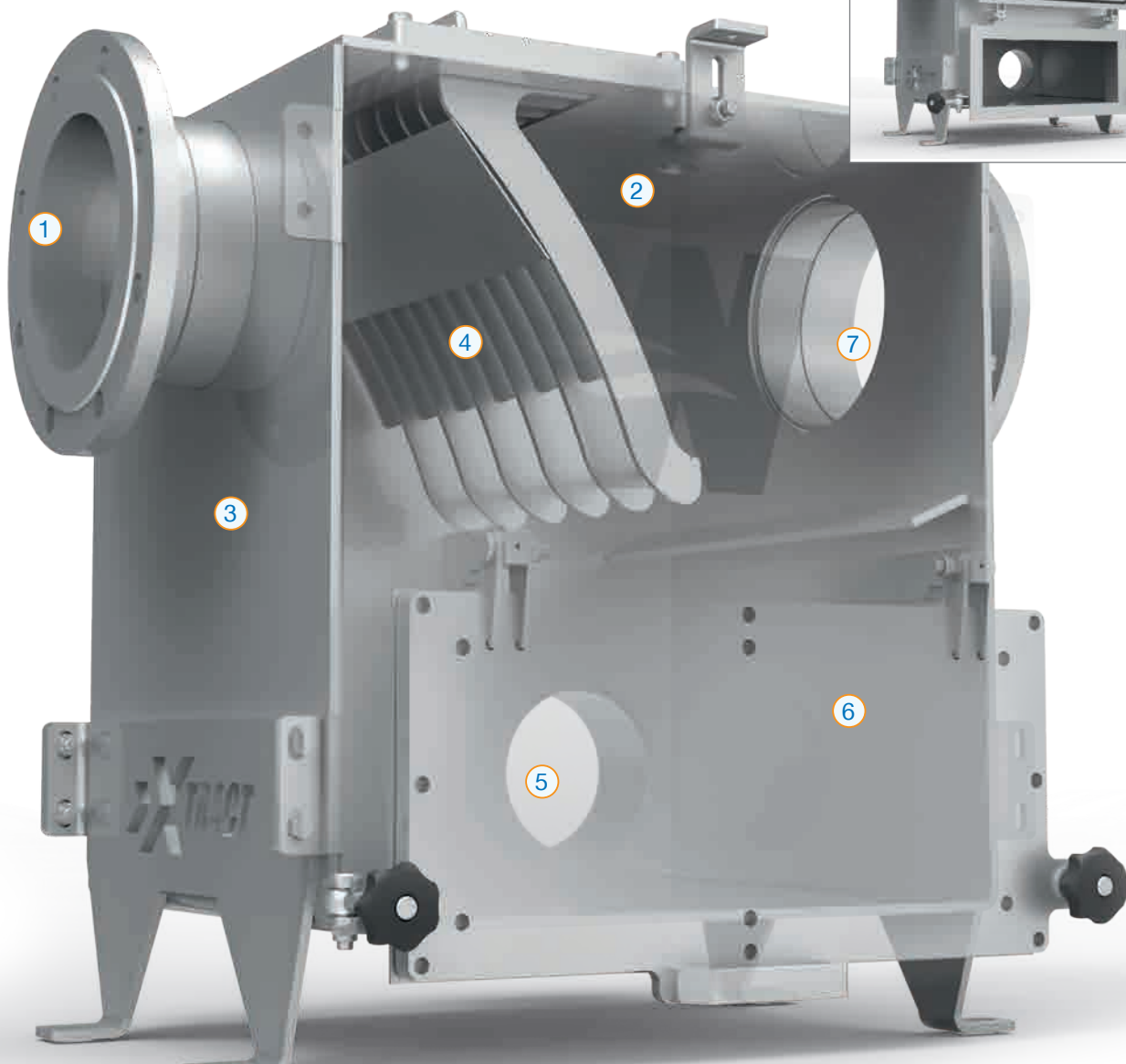

The cutting module as an extension to the X-TRACT

WANGEN X-CUT

No external lifting device necessary

for installation and dismantling of the wear parts by a moveable drive unit.

Avoidance of wear, system shutdown and damage

through cutting of foreign bodies to unproblematic lengths and/or sizes.

Increased process safety

through further use of the X-TRACT also in case of dismantled X-CUT by means of installation of a blind cover on the flange.

Further plus points:

- Very rugged implementation.
- Compact, space-efficient construction design.
- Cutting tool consisting of 4 hardened, tool-steel blades.
- Long service lives due to high-quality materials and turning blades. Therefore low life-cycle costs, thanks to low wear costs of the cutting unit.
- Simple and rapid replacement of the cutting knives by means of central tensioning screw.
- Powerful motor guarantees reliable cutting.

The WANGEN X-CUT is a module for the cutting of foreign bodies in the pumped medium. The cutting unit can be adapted optimally to the pumped medium by simple modification. As a result of this, blockages in the system, for example plaited knots or similar, are avoided. Optimum function in extension with the WANGEN X-TRACT.

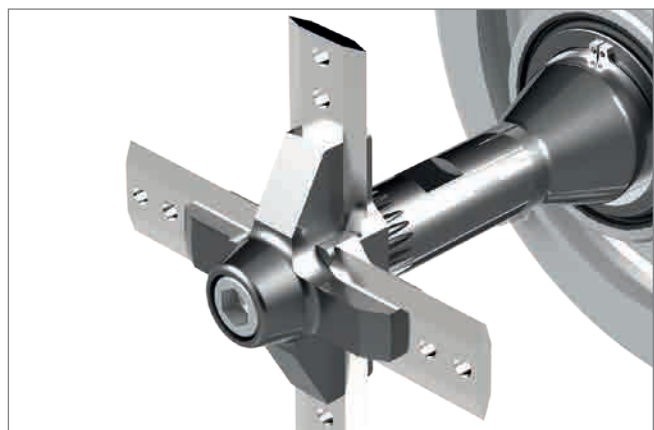
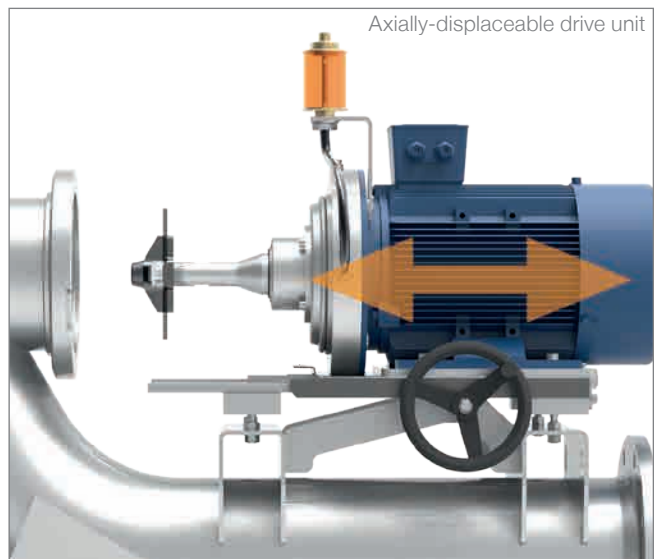
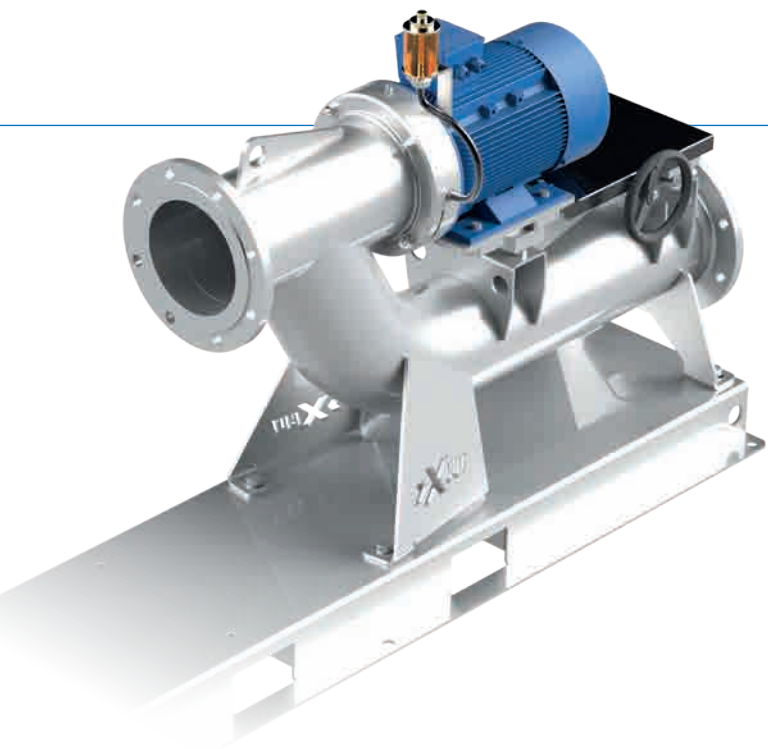

X-CUT design components:

- ① Media inlet
- ② Cutting unit / shredding tool (rotating cutter)
- ③ Storage tank for mechanical seal oil
- ④ Drive unit
- ⑤ Outlet
- ⑥ Retractable maintenance table
- ⑦ Media outlet

Material: Galvanized mild steel (further materials on request).

Maximum capacity: 330.004 gph (1,250 m³/h / 347 l/sec).

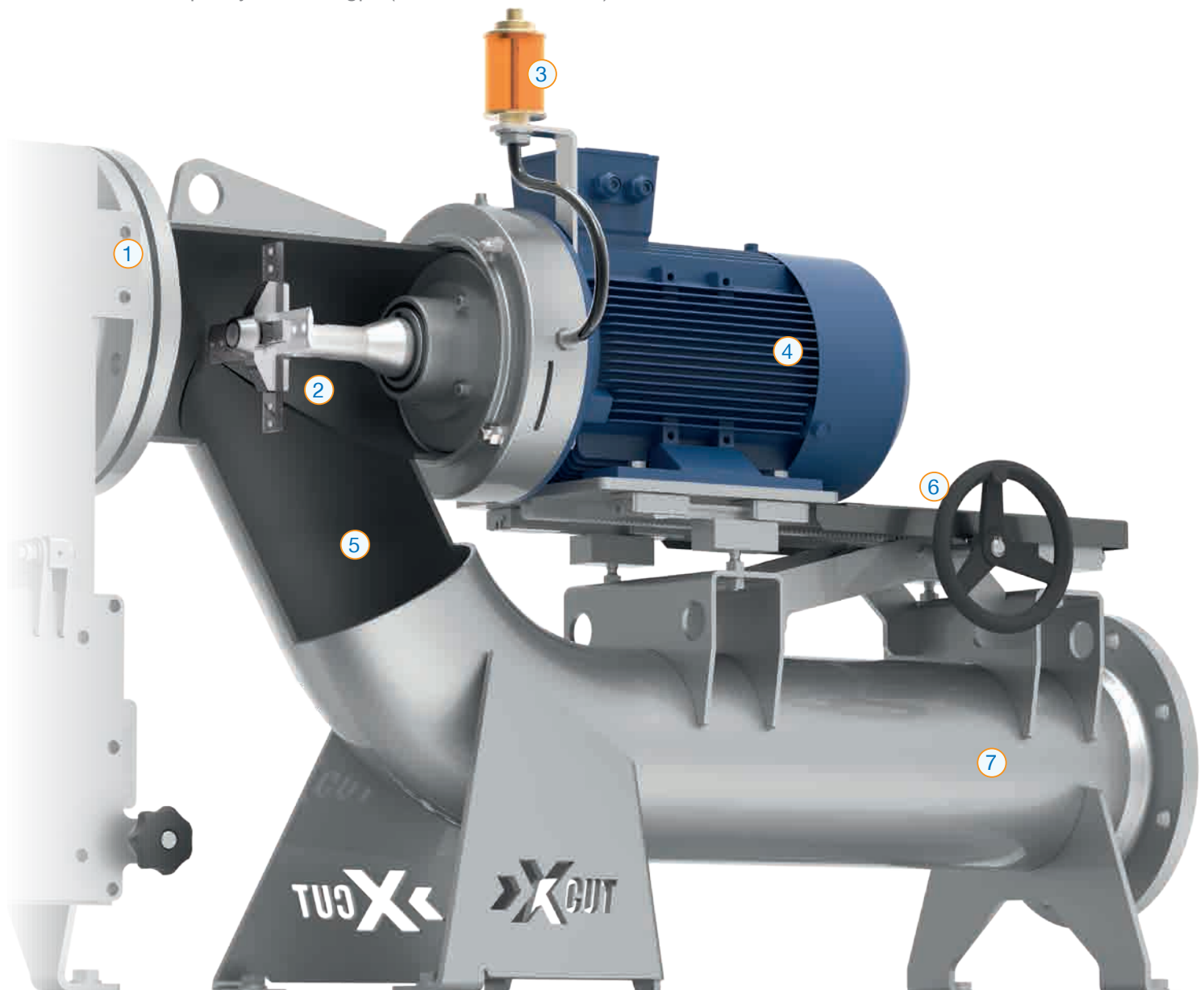

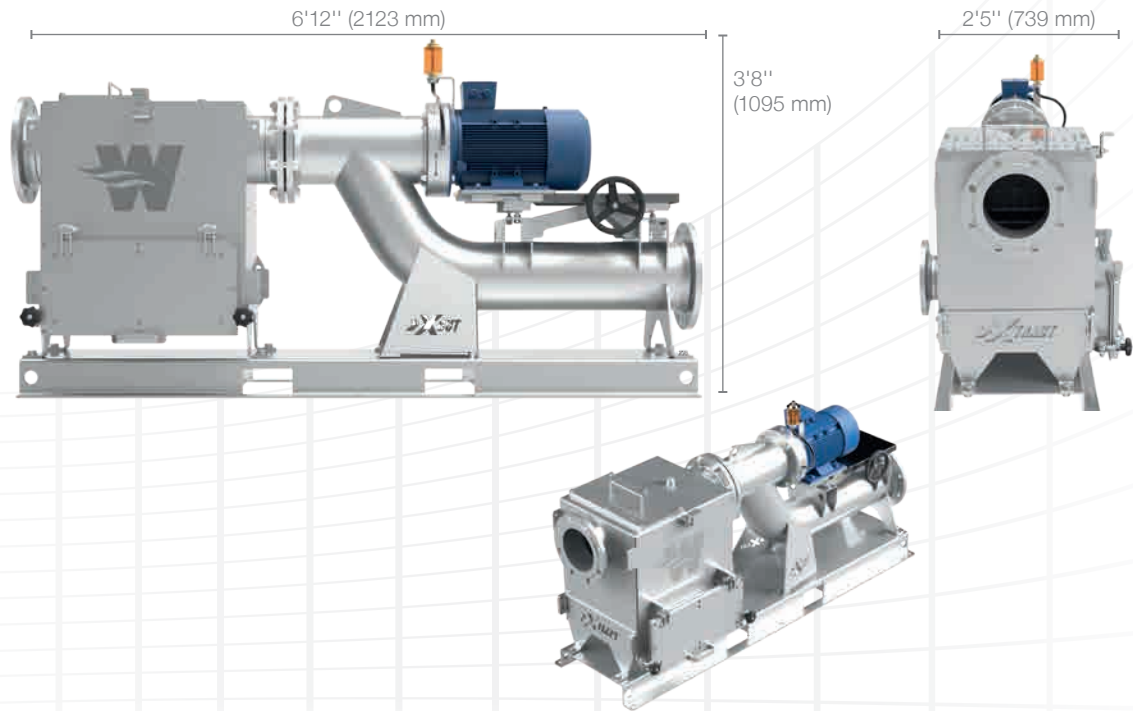

Quality and Environmentally committed

WANGEN PUMPEN is ISO 9001 and ISO 14001 certified.



Represented by:

KGGO
Group Ltd.

"The Benefit of Experience"

Engineered pump
& process systems



2172 Wyecroft Road, Unit 4&5
Oakville, Ontario L6L 6R1
Canada
Tel: 905.847.1544
Fax: 905.847.1699
info@kgogroup.com

www.kgogroup.com



Wangen America, Inc.

925 Cambridge Drive
Elk Grove Village,
IL 60007
USA

Pumpenfabrik Wangen GmbH

Simoniusstrasse 17
88239 Wangen im Allg.
Germany
www.wangen.com



Product video