

Sanitary progressing cavity and hopper feed pumps
**HYLINE, KB-SL, KL-SL, KL-RL,
KL-RF, KL-TL / KB-TL**

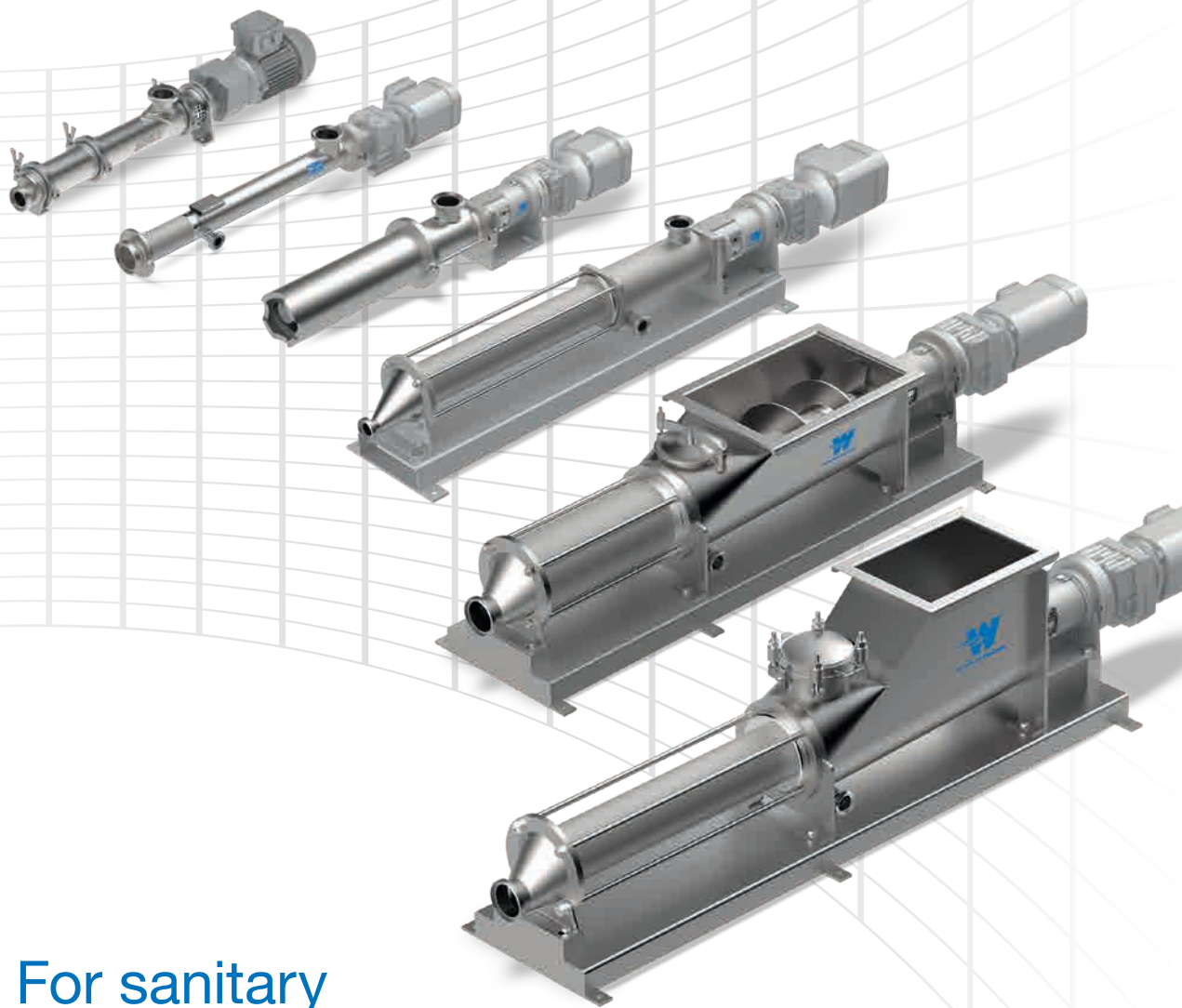

For sanitary
pumping processes with low
to extremely high viscosity mediums



WANGEN sanitary self-priming and hopper feed pumps

KB-SL, KL-SL, KL-RL, KL-RF, KL-TL / KB-TL

A high degree of automation and fast product turnover are characteristics of the modern meat processing industry. Fruits and vegetables depend on freshness and quality. The confectionery industry works with different kinds of ingredients, which vary from viscous to sticky, may come in pieces or are sensitive to shearing forces. Diversity, good taste, and reasonably priced, that is the baker's ideal range of goods. Manufacturers of beverages must be able to compete in an increasingly globalized market, but at the same time offer the right product mix, quality, and price. The same applies to the milk processing industry.

As varied as the requirements, provisions, and areas of use may be, all the more individual are our solutions. However, one important point remains the same: satisfying the customers' highest quality requirements and specifications, especially in terms of hygiene. This has been a crucial aspect for us for a number of decades.

Technical highlights:

- Flowrate 0.04 – 1144.75 gpm,
- Temperature from 22 °F up to 284 °F,
- Max. differential pressure 696.18 psi,
- Viskosity up to 200.000 cP.

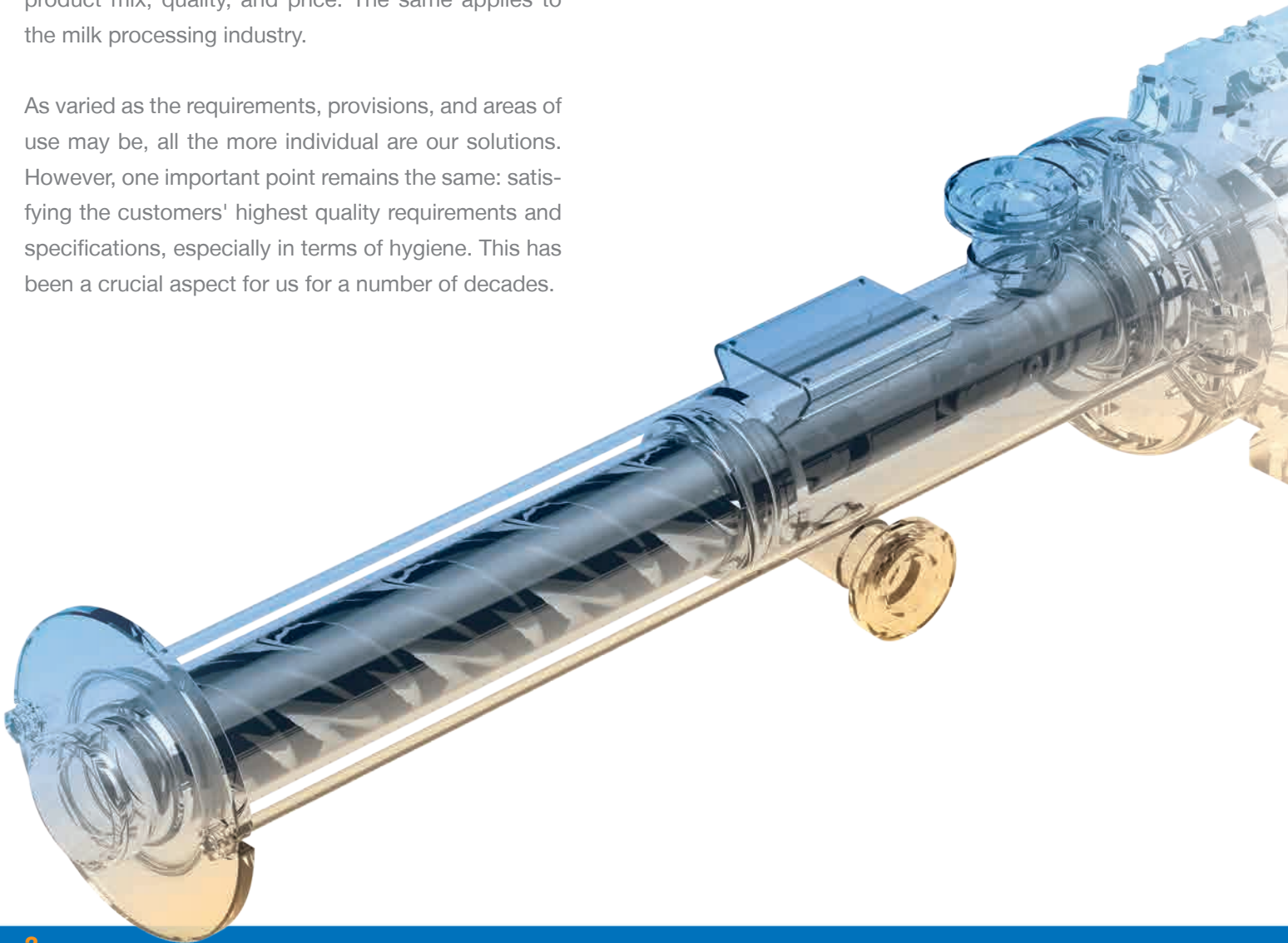

Applications

Conveying Materials

The progressing cavity pumps of the series KB-SL, KL-SL, KL-RL, KL-RF and KL-TL/KB-TL are typically used to pump the following mediums:

- Apples, pears, and other fruit
- Vegetables
- Grain and/or coarsely ground cereal
- Pastes
- Dairy products, such as butter, milk, yoghurt, ice cream, processed cheese
- Meat varieties and tofu
- Honey, caramel, gelatine, jam
- Confection, such as chocolate, liquid sugar, marzipan or waffle mass
- Beverages, such as fruit juices, beer
- Mustard, ketchup, soy sauce, tomato paste or mayonnaise
- Cosmetics, such as shampoo or soap



Properties

We always have the overall process in mind

We see ourselves not just as a supplier of individual components. Our objective is rather to find the best solution for the entire production process. We achieve this by exact observation and analysis of the overall process. You receive a solution to match your requirements that was precisely assessed and prepared by the specialists from WANGEN AMERICA.

Whether complex or simple, we guarantee the best possible integration of our machines into your existing or new plant system. You will not only benefit from our expertise in mechanical engineering, but also from our many years of experience and the claim to provide our customers with the best possible answer possible, taking into account all relevant factors.

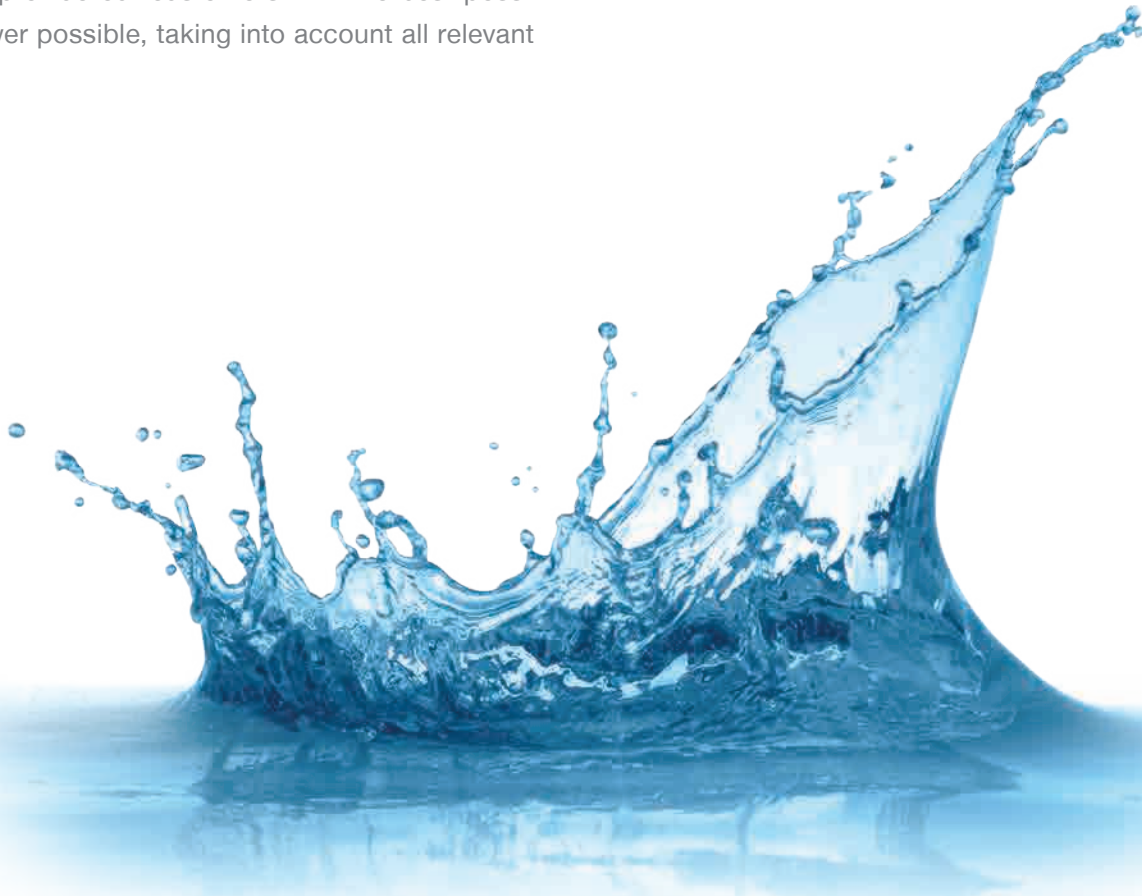

Properties

Highest standards of hygiene

We take our responsibility towards humanity very seriously, especially when it comes to sanitary pumps. For this reason, particular importance is placed on the highest precision and care in the production process at WANGEN AMERICA. It is our goal to make the entry of bacteria and germs into our pumps as well as the living conditions as difficult as possible.

We achieve this by using consistent and uncompromising production according to the highest hygiene standards. This also includes the special design and surface characteristics of our pumps and their assemblies, which avoids producing deposits forming in the casing during the production cycle.

Our customers in the milk processing industry appreciate this because dairy products are especially vulnerable to micro-organisms in regard to the aspect of hygiene.

Thus, we are in a position to produce certain series of pumps according to the highest hygiene requirements of the EHEDG (European Sanitary Engineering & Design Group) for certified manufacturing procedures.



Properties

Construction Characteristics

Cutaway
model:
KL30-SL

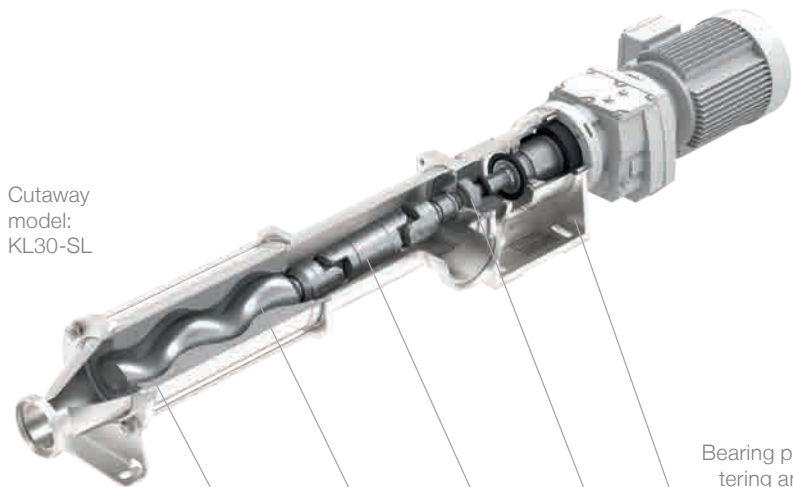

Bearing pedestal with self-centering and direct flange-fitting of the drive unit. This avoids damage to the gearbox.

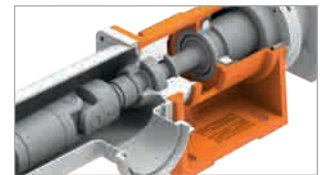

Main sealing material washed optimally within the product room as a mechanical seal.

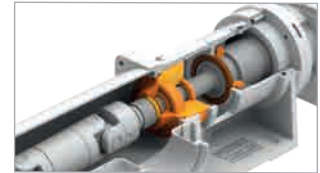

Cardan shaft and joints in stainless steel, open design for ease of cleaning ability

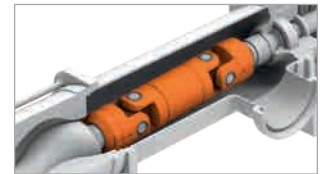

Robust rotor of the highest quality from our own production available in various shapes

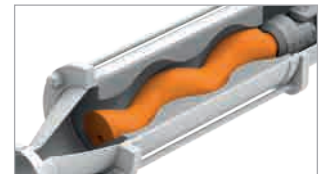

Stators in various shapes from our own production

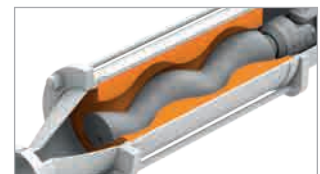

The construction of our pumps shows that they are consistently built for performance and reliability. For example, pumps of the KB-SL series are manufactured as a block construction, which completely suffices for media which e.g. exert only a lower impact on the pump, whereas the construction series KL-SL has a lot more alternatives in reserve, and can handle media ranging from highly abrasive and sticky properties to those which are particulate in nature.

Benefits

Maximum Variety

WANGEN progressing cavity pumps have a modular design. A variety of standardised parts is available for each series and enables each pump to be adapted to meet your specific pumping requirements. Regardless of whatever branch of industry you work in, the medium to be pumped and your operatio-

nal requirements: We offer the optimum solution for your application, regardless of the industry you work in, the medium to be pumped, and your operational requirements.

Maximum variability:

- Various construction sizes and rotor/ stator sizes mean more than 100 models of the compact pump with a delivery rate ranging from 0,04 gpm up to large pumps which can handle flowrates up to 1144.75 gpm.
- A availability of a large variety of designs and materials for casings, rotors, stators, seals, joints ensure that optimum adaptation to the medium to be pumped can be achieved.
- Our broad spectrum of flange connections and drive units assures that the best possible solution for your installation and available space can be found.

We shall be pleased to develop an individual solution for your special design.

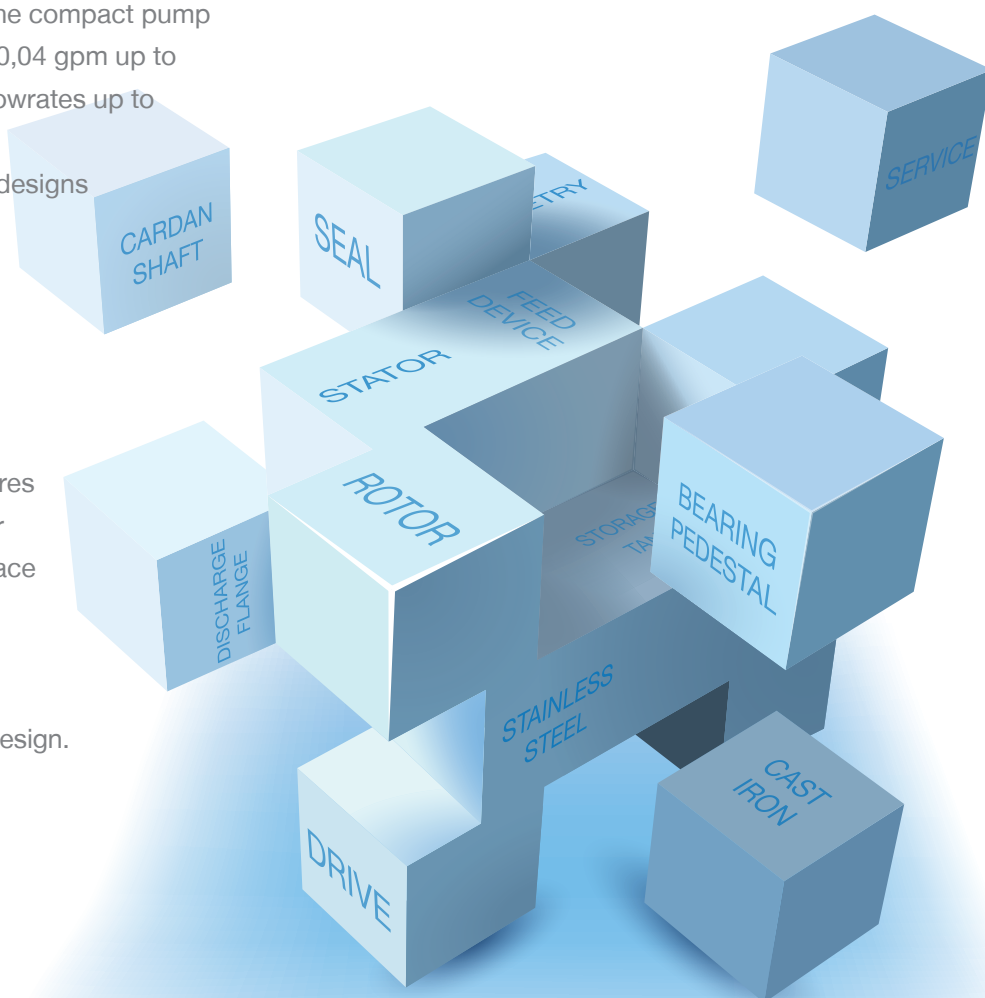

Benefits

Low Life-Cycle Costs

When purchasing a pump, we recommend that you carefully consider the operating costs as well as the costs for the initial purchase. Maintenance costs, production downtimes, and energy costs make up a considerable share of the total costs over the life-cycle of a pump.

Our philosophy is to keep the total costs of the entire pump life-cycle as low as possible by reducing needed maintenance to a minimum. This is possible due to our robust pump construction, the use of high quality wearing parts, and a wear-resistant design of the pumps.

Every avoided breakdown saves you expenses for spare parts, maintenance work, and production downtime. This ultimately results in saving money, but also reduces stress due to a smoother operating process.

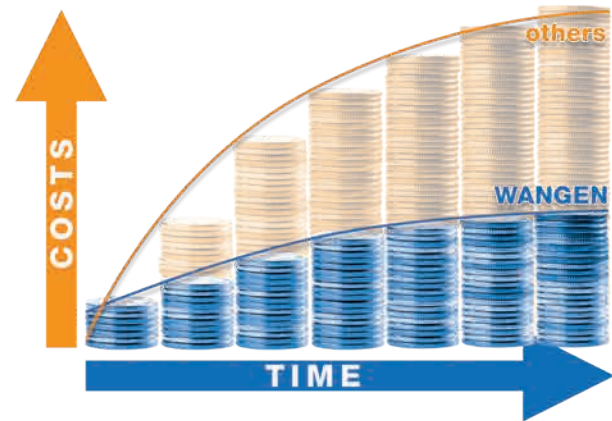

Easy Maintenance

In order to ensure the high availability of plant and equipment, many of our customers want to service their pumps themselves. For this reason, our pumps possess large inspection covers, for example, or maintenance-free components, such as the flexible rod, especially when it comes to the aspect of hygiene. A change of rotor and shaft seal is also simple to perform, thanks to the good accessibility of the connecting bolts. The fact that WANGEN PUMPEN, amongst other things,



comply with the highest hygiene standards is also due to the optimized, low dead-space design and construction of our pumps over the decades.

Technical Data

Versions and Materials

There is a large selection of standardized construction parts available for the design of your standard suction pump. We provide economical and optimized pumping solutions that are customized for your industry and operating conditions.

- Casing, pressure and suction flange: Stainless steel 1.4301 (A304), stainless steel 1.4571 (A316Ti)
- Joints: stainless steel cardan joints, optionally with sleeve
- Seals: single and double-effect mechanical seals
- Drive unit: gearbox motors, hydraulic motors
- Stators: diverse NBR materials, FPM, silicon, EPDM, pressure-stable 'even wall' designs, solid substance stators made of POM
- Rotors and stators in up to 8 pressure classes and available as S-, L- and H geometric forms

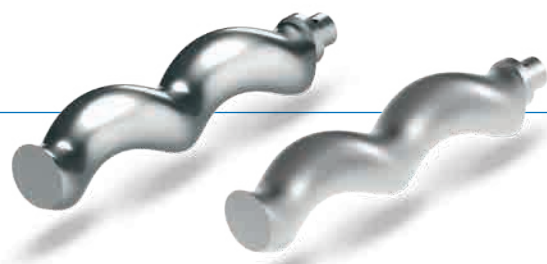

Options and Accessories

We offer a large selection of accessories which are perfectly matched to our product range, providing the ideal complement or adaptation to your individual requirements and allowing you to create your own customized solutions. We would also be happy to advise you here, as special solutions are of course also possible.

- Mounted on a baseplate or used as a mobile pump in the production plant
- Temperature and pressure sensors to prevent the pump running dry and the excessive build-up of pressure
- Frequency converter to regulate the delivery volume
- Cardan joint with feed screw for pumping very viscous media
- Pump manufactured in accordance with the ATEX guidelines for use in potentially explosive areas



Spare Parts

By using spare parts from WANGEN PUMPEN, we guarantee that the performance output of our pumps will be fully restored. With our decades of manufacturing experience, you will be able to profit from our first class quality as a manufacturer and, as a consequence, ensure the long service life of your pump.

Technical Data

Performance Data HYLINE

The WANGEN HYLINE is designed by WANGEN PUMPEN to ensure optimal performance and operational reliability. The inner geometry of the housing is designed fully hygienically and, as is usual with WANGEN PUMPEN, suited to long life.

The flexible and maintenance-free joint is coated with elastomer and offers almost no weak spots for disposals of the media to be pumped. In order to enable the conveyance of a wide spectrum of media, a large selection of shaft seals are available for the HYLINE.

Pump size	Maximum particle size (inch)	Flowrate (gpm)	Maximum differential pressure (bar / psi)
20	1.024	0.088 – 29.06	20 / 290

elastomer-coated,
maintenance-free
joint

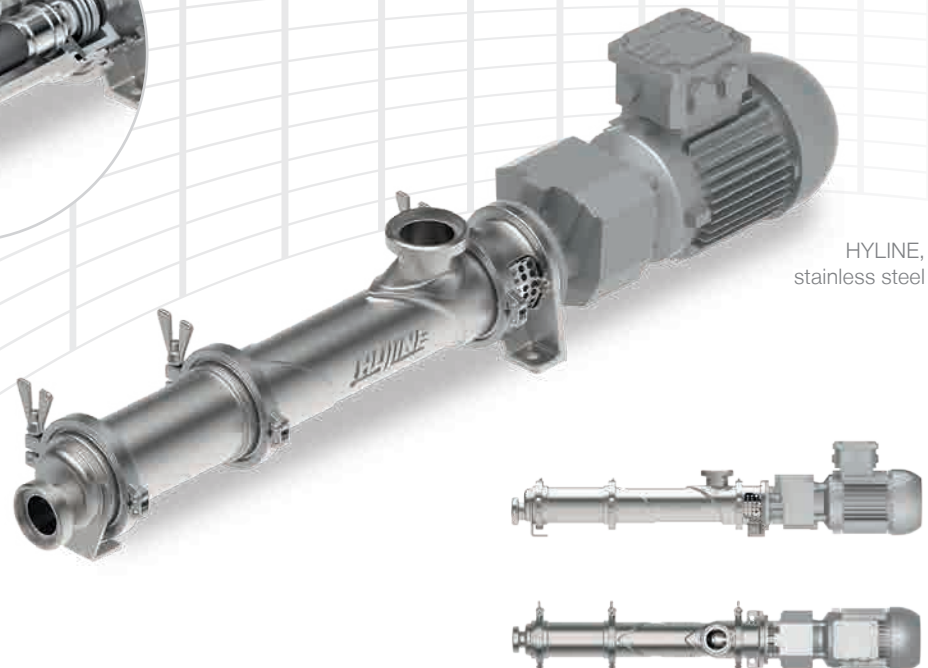
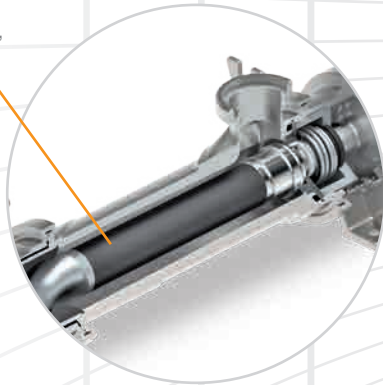

Technical Data

Performance Data KL-TL / KB-TL

The WANGEN progressing cavity pump type KL-TL / KB-TL is suitable as an immersion pump for pumping mediums out of tanks and basins. Regardless of the medium's consistency, it is conveyed as careful as possible without impairing its structure and quality. The joint connections retain an uniform diameter and ensure constant flow rates, the low-pulsating and

continuous pumping action of the media is independent of pressure and viscosity. A further benefit is the high level of operating safety. The configuration and length of the pump can be customized to meet the needs of the client.

Pump size	Maximum particle size (inch)	Flowrate (gpm) at 350 rpm	Maximum differential pressure (bar / psi)
20	0.94	0.15 – 9.25	12 / 174
30	2.00	1.5 – 140.90	12 / 174

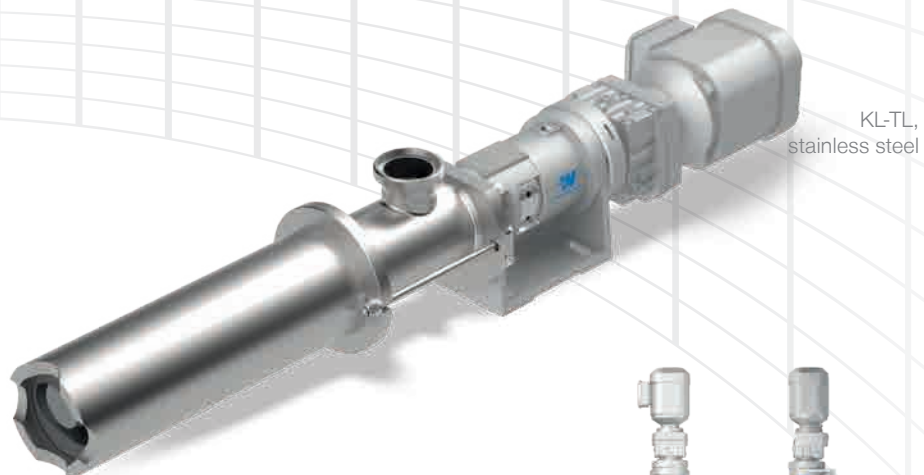

Technical Data

Performance Data KB-SL

The WANGEN progressing cavity pump type KB-SL Sanitary is a further development of the pump construction series for the food industry. In this area, where there is contact with the product, the stainless steel of the „hygienic“ version, after grinding and electropolishing, has a surface roughness of $RA < 0.8 \mu m$. Further quality characteristics are the

gentle way the product is pumped, the dead-space and low stagnation space design, the high availability as well as the low maintenance requirement, the high dosing accuracy also at low rotational speeds and the extremely high level of safety in operation. The KB-SL is available optionally with one or two tangentially inclined cleaning connections.

Pump size	Maximum particle size (inch)	Flowrate (gpm) at 350 rpm	Maximum differential pressure (bar / psi)
20	0.94	0.04 – 20.25	48 / 696.18

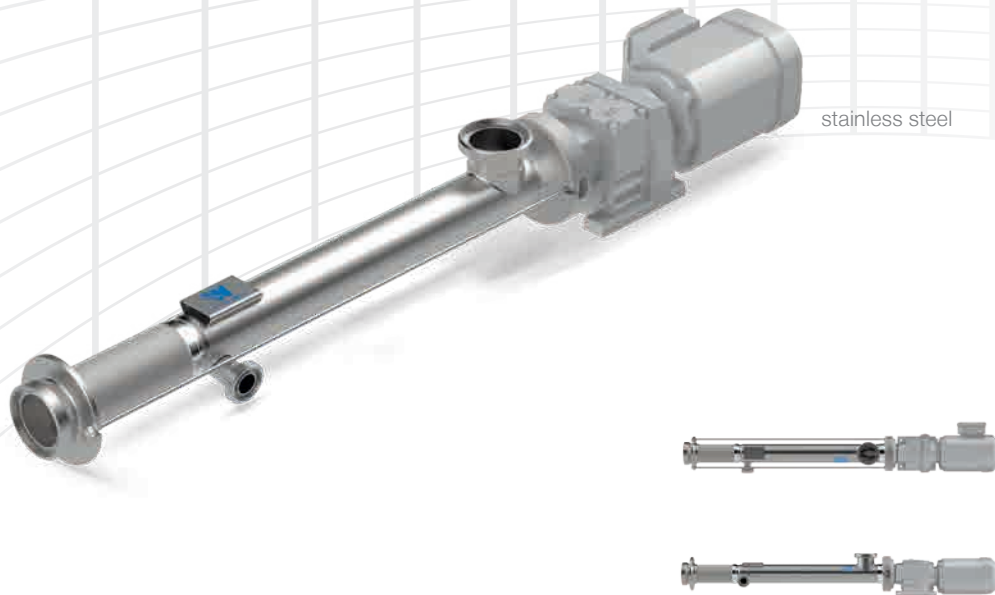

Technical Data

Performance Data KL-SL

The pumps of the KL-SL series convince with their ease of cleaning and low dead-space construction. In this area, where there is contact with the product, the ground, electropolished stainless steel of the EHEDG-certified version „Hygienic“ has a surface roughness of RA < 0.8 µm. Depending on the medium to be pumped, the pump can optionally be

operated in a heating or cooling mode. Further quality characteristics are CIP (Cleaning in Place), low pulsation, and continuous pumping independent of pressure and viscosity. It is able to cope with longer distances and big differences in height. The KL-SL is absolutely easy to maintain and also impresses by its high level of operational safety.

Pump size	Maximum particle size (inch)	Flowrate (gpm) at 350 rpm	Maximum differential pressure (bar / psi)
20	0.94	0.04 – 20.25	48 / 696.18
30	2.00	0.15 – 140.90	48 / 696.18
50	3.23	1.50 – 431.48	48 / 696.18
65	3.74	5.35 – 1144.75	48 / 696.18

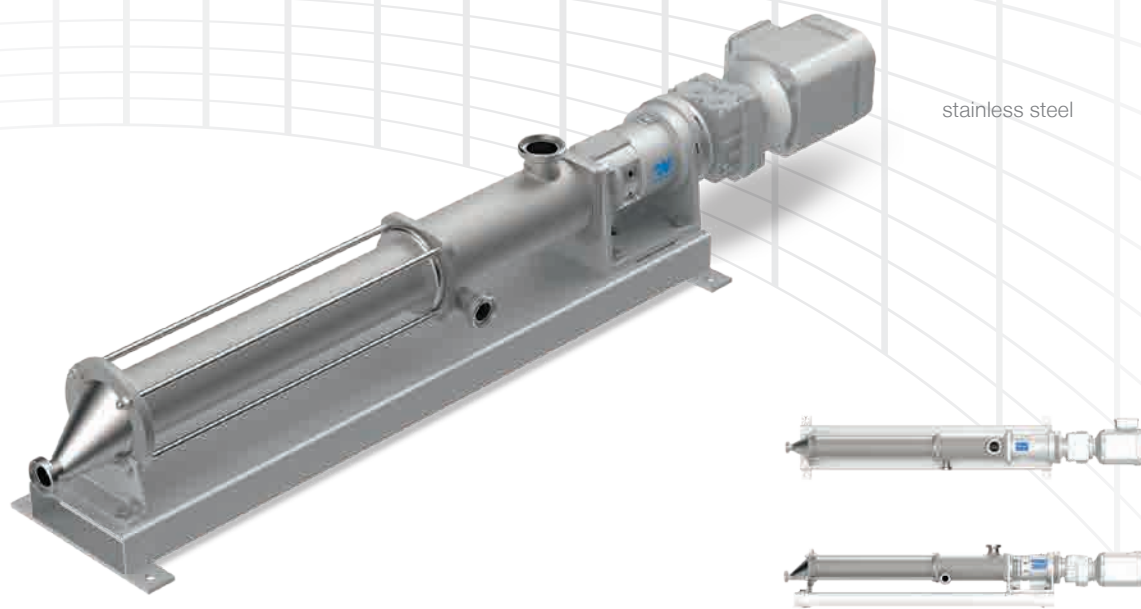

Technical Data

Performance Data KL-RL

Pumps of the series KL-RL allow almost pulsation-free pumping of mediums. The large hopper with screw conveyor has only a minimal dead space, despite the compact construction form, and avoids stagnation zones due to its special design. The stator is equipped with a funnel-shaped inlet for optimal filling of the feed chamber. In areas which come into

contact with product, the ground, electropolished stainless steel of the EHEDG-certified „Hygienic“ version has a surface roughness of $RA < 0.8 \mu m$. Depending on the medium to be pumped, the pump can be operated with heating or cooling options, and a variation using an attachable hopper is also possible.

Pump size	Maximum particle size (inch)	Flowrate (gpm) at 150 rpm	Maximum differential pressure (bar / psi)
30	2.00	59.44	48 / 696.18
50	3.74	198.13	48 / 696.18
65	3.74	285.31	48 / 696.18

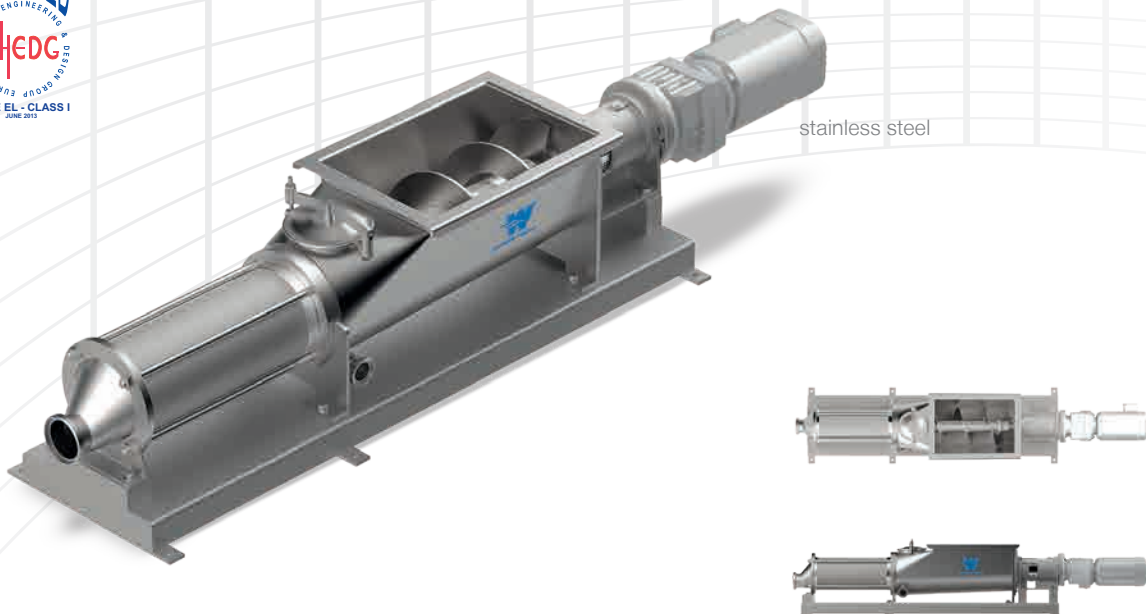

Technical Data

Performance Data KL-RF

Pumps of the series KL-RF have an inspection cover, a maintenance-free mechanical seal, which is independent of the rotation direction, and the discharge nozzle has a self-emptying design. The KL-RF is available with different rotor/stator geometric forms (S-, L- and H shapes). Products are pumped in a particularly gentle way and can be optionally hea-

ted or cooled. A strength of the KL-RF is its use in plasticising blocks of fat or butter. Upon request, feed aggregates are also possible in special designs, as well as a version with an extension funnel.

Pump size	Maximum particle size (inch)	Flowrate (gpm) at 50 rpm	Maximum differential pressure (bar / psi)
30	2.00	19.81	48 / 696.18
50	3.74	66.04	48 / 696.18
65	3.74	96.86	48 / 696.18

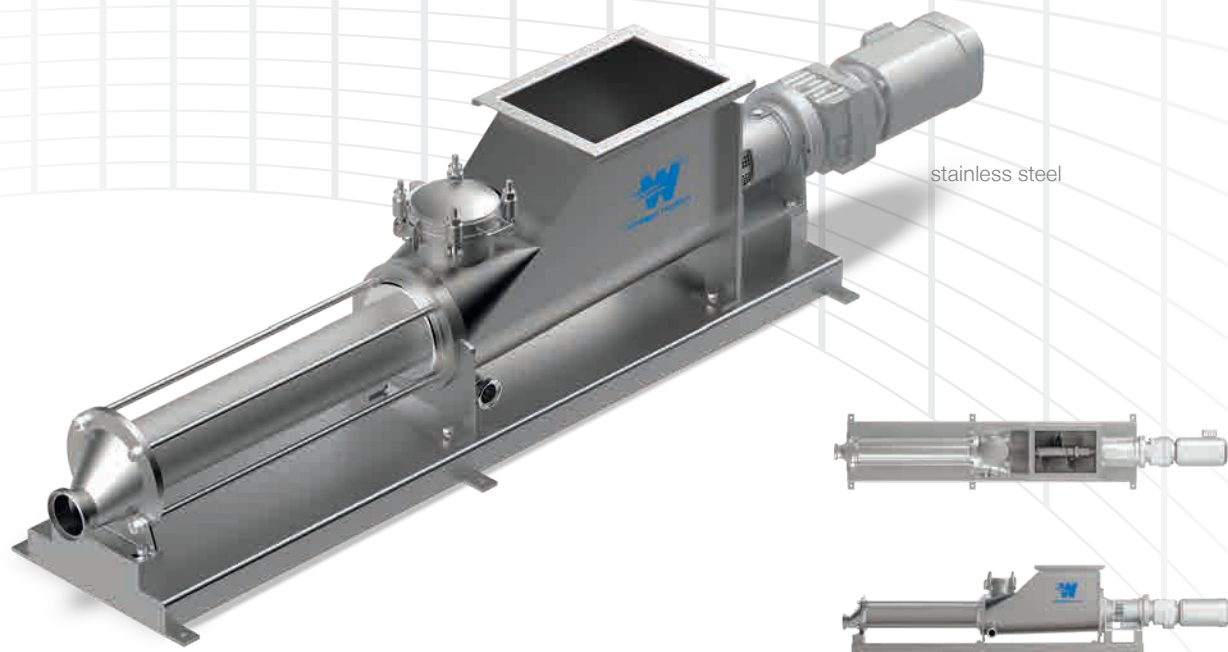



Quality and Environmentally committed

WANGEN PUMPEN is ISO 9001 and ISO 14001 certified.



Represented by:

**KG
Group Ltd.**

"The Benefit of Experience"

Engineered pump
& process systems



2172 Wycroft Road, Unit 4&5
Oakville, Ontario L6L 6R1
Canada
Tel: 905.847.1544
Fax: 905.847.1699
info@kgogroup.com



www.kgogroup.com

Wangen America, Inc.
925 Cambridge Drive
Elk Grove Village,
IL 60007
USA

Pumpenfabrik Wangen GmbH
Simoniusstrasse 17
88239 Wangen im Allg.
Germany
www.wangen.com

No. ED705

05.2019

© 2019 Pumpenfabrik Wangen GmbH. Subject to errors and technical changes.