

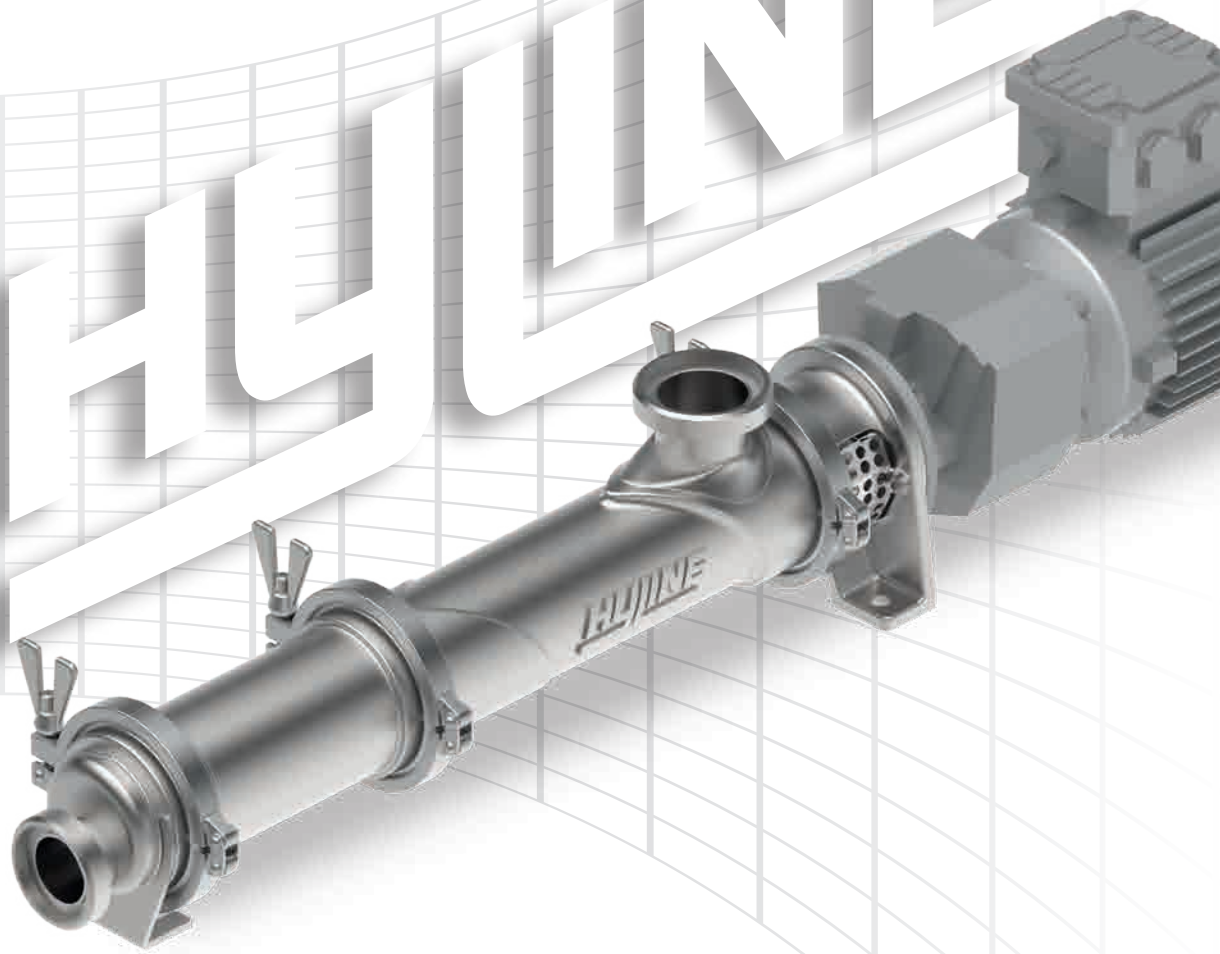

Hygienic Progressing Cavity Pump
WANGEN HYLINE



For sanitary conveying and dosing in
the food & beverage-, cosmetics- and
pharmaceutical industry

WANGEN HYLINE

Features and characteristics

The WANGEN HYLINE is designed by WANGEN PUMPEN to ensure optimal performance and operational reliability.

The sanitary-related design of the WANGEN HYLINE was implemented according to the strict GMP (Good Manufacturing Practice) Directives, which are assuming an increasingly important role in the food, pharmaceutical and cosmetics sectors. For this purpose, as is usual with WANGEN PUMPEN, special value is placed on quality - and this means on lifetime duration.

Hygienic Highlight: The flexible and maintenance-free joint is coated with elastomer. A constant shaft diameter construction design prevents sedimentation of the media to be pumped.

In order to enable the conveyance of a wide spectrum of media, a large selection of single-acting and double-acting shaft seals are available for the HYLINE, such as the encapsulated seals, single acting seal with elastomer bellows or gland packing.

The intelligent design of this sanitary pump requires no additional seals in the product chamber. Pump disassembly is easily carried out by removing all pump component connections outside the product chamber.

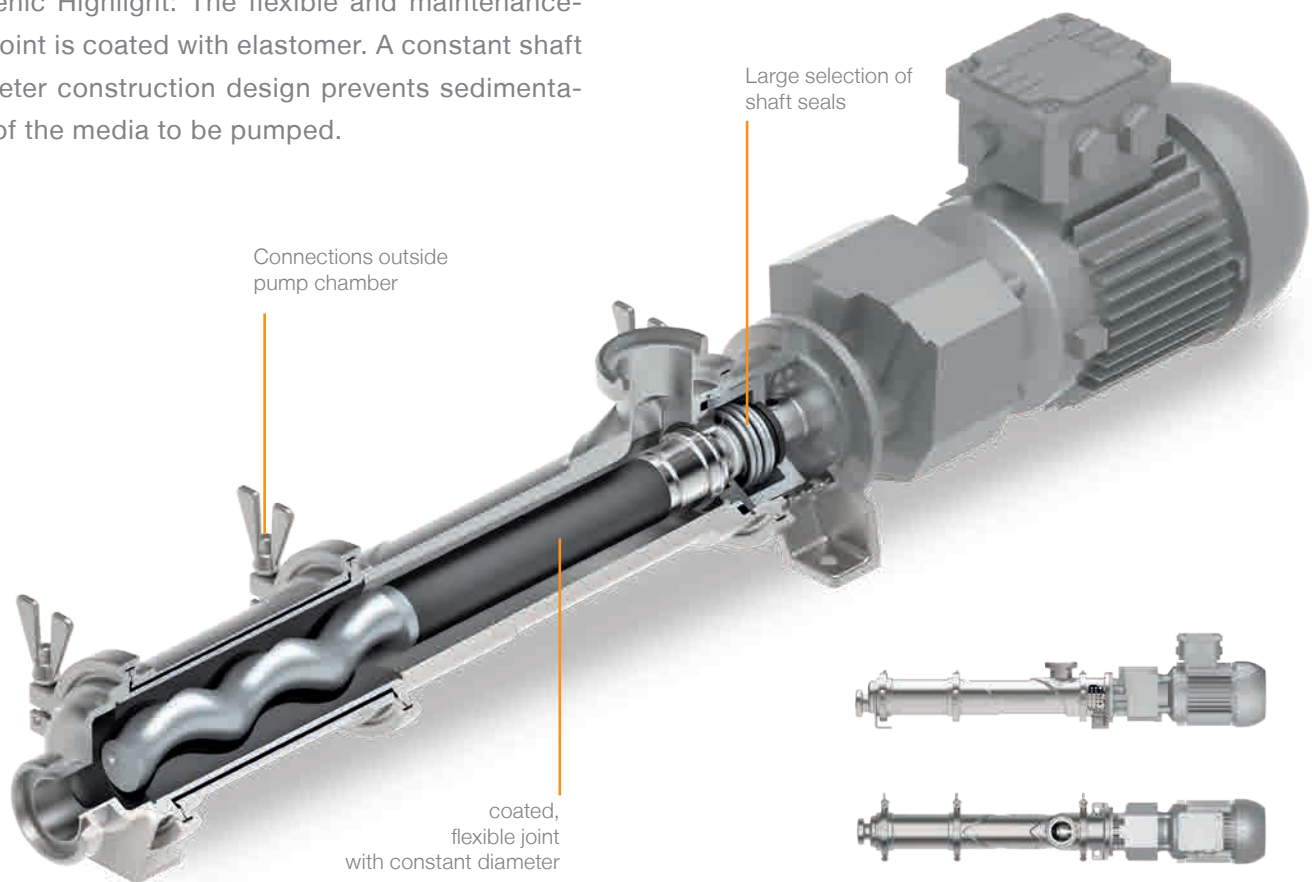

Technical data and properties

Performance data WANGEN HYLINE

Pump size	Maximum particle size (inch)	Flowrate (gpm)	Maximum differential pressure (bar / psi)
20	1	0.09 up to 30	20 / 290

Characteristics:

- Designed according to the strict directives of EHEDG, 3A and GMP
- Low dead space design for optimal cleaning capability
- Temperature -22 °F - 284 °F
- Viscosity up to 100,000 cP

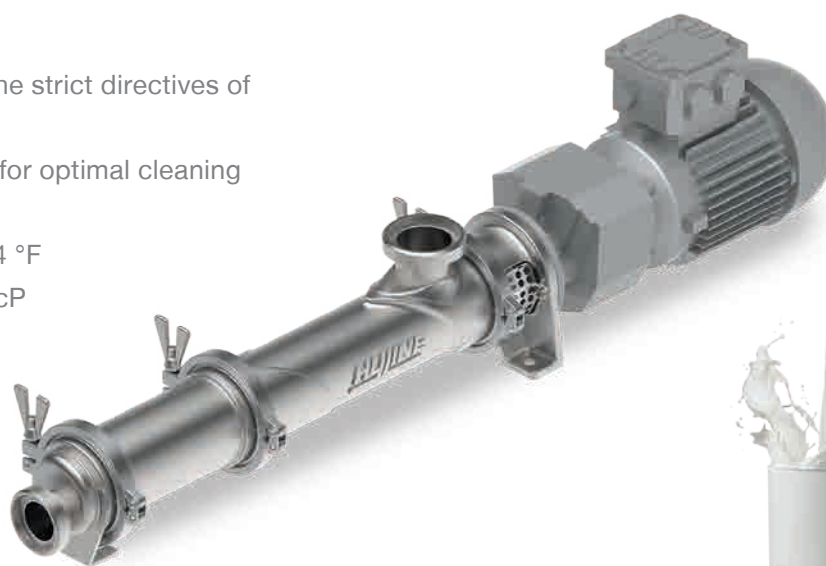

Conveying media:

- Dairy products, such as butter, margarine, milk, yoghurt, processed cheese
- Drinks, such as fruit juice, beer
- Confectionery, such as chocolate, liquid sugar, marzipan, waffle mass, fondant mass or glazes
- Mustard, ketchup, mayonnaise, soy sauce or tomato pureé
- Pastes
- Honey, caramel or gelatine
- Ice cream, jam
- Pet food
- Cosmetics, such as shampoo, face cream or soap
- Pharmaceutical products





Quality and Environmentally committed

WANGEN PUMPEN is ISO 9001 and ISO 14001 certified.



No. EO333

05.2019

© 2019 Pumpenfabrik Wangen GmbH. Subject to errors and technical changes.

Wangen America, Inc.
925 Cambridge Drive
Elk Grove Village,
IL 60007
USA

Pumpenfabrik Wangen GmbH
Simoniusstrasse 17
88239 Wangen im Allg.
Germany
www.wangen.com