

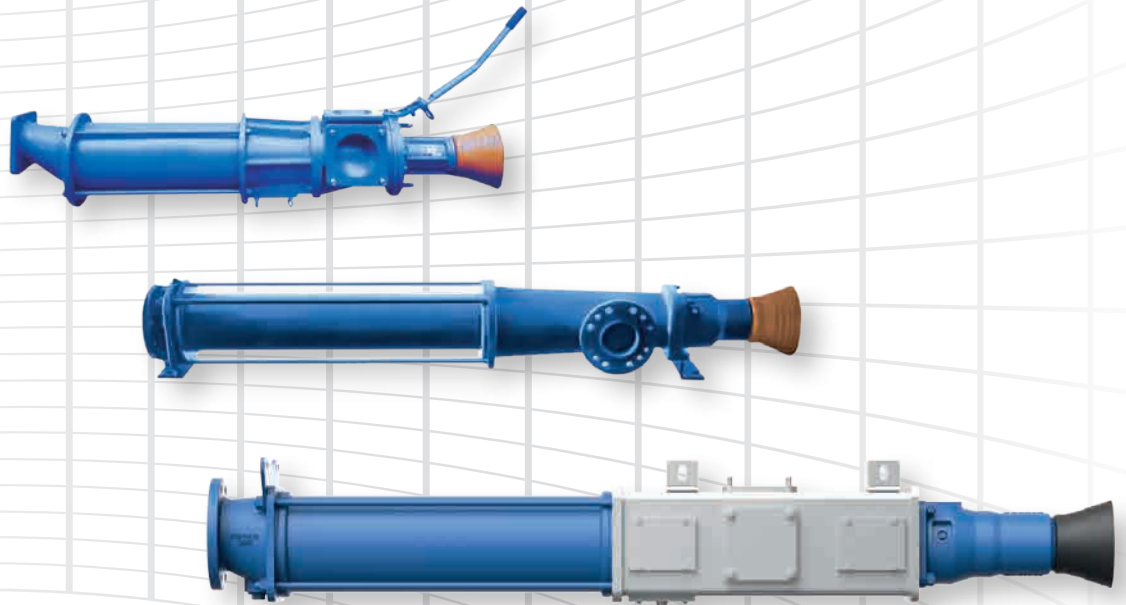

PTO shaft pumps
A, GL-F, GL-S



The robust solution for the conveyance of manure, sludge, and fermenter substrate

WANGEN progressing cavity pumps

PTO shaft pumps A, GL-F, GL-S

WANGEN pumps can be driven via power take-off as well as via electrical, hydraulic or diesel motor. According to requirements, they can be designed for stationary use or for mobile use on 2-wheeled wagons. Alongside the three-point bracket mount, they may also be mounted directly to the manure tanker, for example, for the distribution of water, slurry, and thick mediums, such as manure or sludge. Then, they are driven directly via the power take-off profile connection of the tractor.

Numerous versions, sizes, as well as modular pump construction of the A, GL-F and GL-S and sizes ensure that you are able to find a pumping solution that is tailored to your individual application.

Technical highlights:
flowrate up to 2,113 gpm,
temperature up to + 176 °F,
max. differential pressure 174 psi,
high solids content of up to 18%

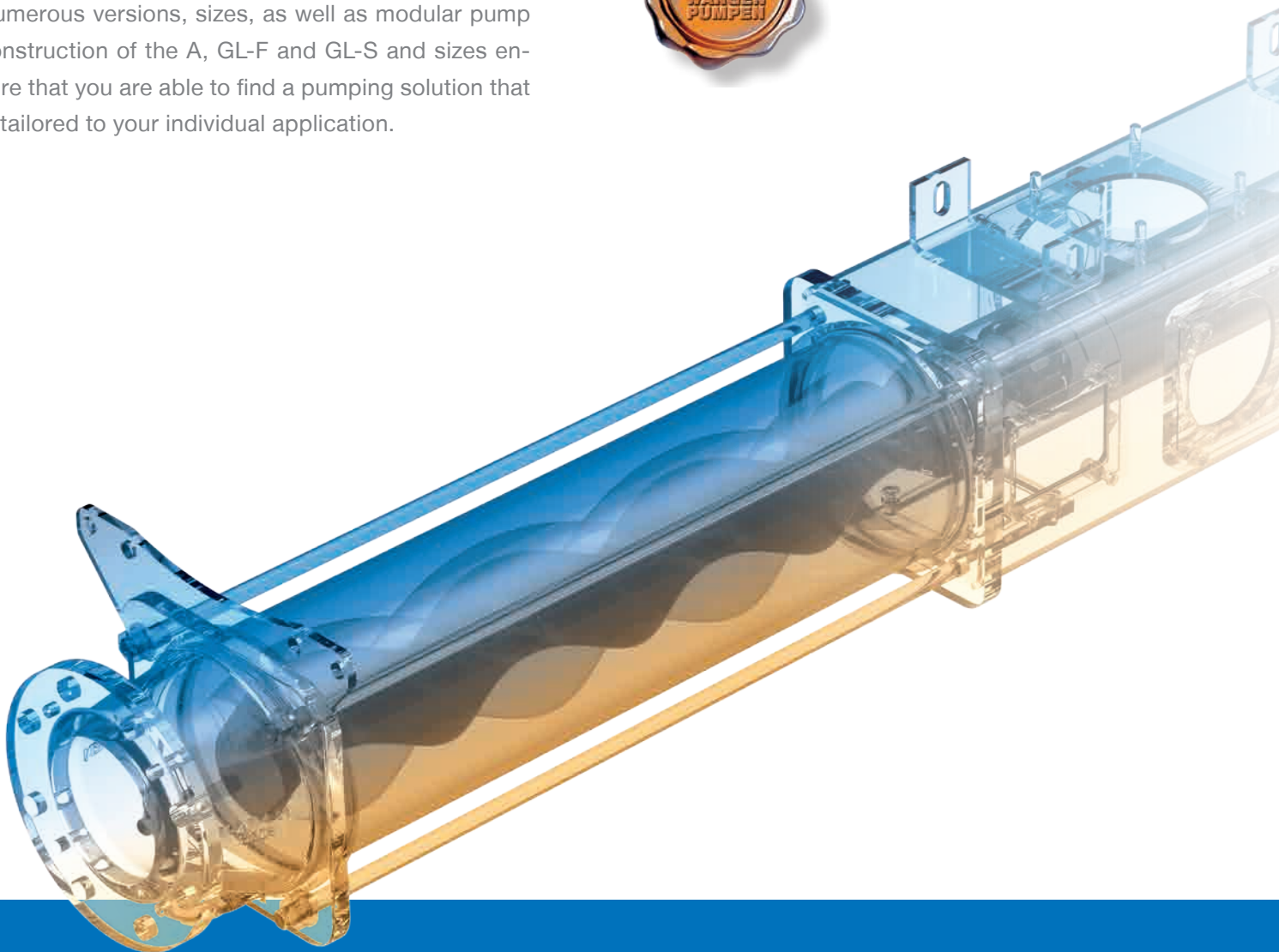

Applications

Conveying Materials

With the power take-off pumps A, GL-F and GL-S, the following mediums are typically conveyed:

- Fertilizers
- Manure, from cattle or chickens
- Sewage sludge
- Fermenter substrate

The power take-off pumps A, GL-F and GL-S are ideally suited for:

- Distributing
- Pumping
- Filling
- Loading, unloading, transferring
- Sucking



Features

Construction Characteristics

Model:
GL65-F

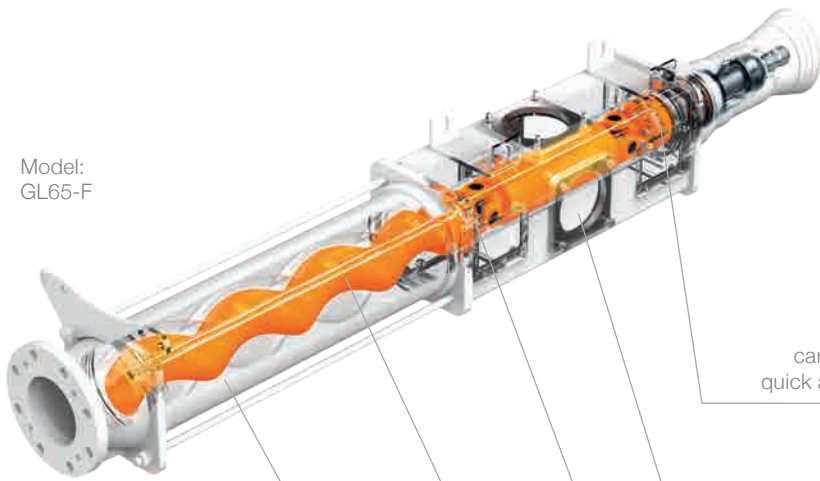

Main sealing in cartridge construction, quick and easy to replace.



Large cleaning and inspection openings



Cardan shaft and joints by default in GL-F. Lifelong permanently lubricated needle bearing. Wear and maintenance-free.



The robust rotor is produced in the highest quality at our own plant. It can be manufactured in various shapes.



Stators in various shapes from our manufacturing plant.

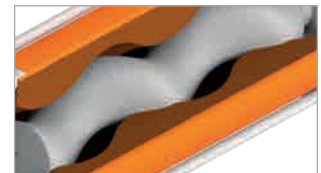

Our aim is to produce the best pumps for the job in hand. For this reason, WANGEN pumps are consistently designed for the highest possible performance and reliability. This can be clearly seen by the construction and the satisfaction of the customers.

Benefits

Maximum Reliability

In agricultural operations, a medium is often conveyed with a high ratio of foreign objects, which often occurs at high pressure or continuous operation. This heavy load often leads to damages with traditional pumps, such as a breaking joints. For this reason, we only use robust components of the best-possible quality for our pumps. In this way, WANGEN pumps need less maintenance and enable an interruption-free operation.

- The bearing block takes the pressure off the joint shaft and prevents damage when used for continuous operation.
- A non-clogging operation is ensured by using fully encapsulated needle bearing cardan joints with a protective sleeve. This increases resistance under heavy loads that are caused by abrasive and fibrous mediums.
- A joint with the same diameter ensures a constant flow speed in the suction housing. This design prevents sedimentation and blocking in the pump.

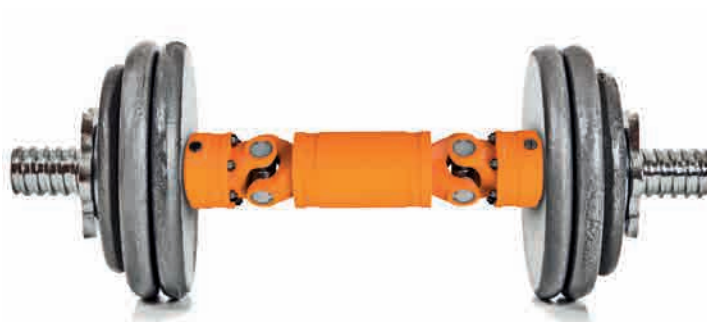

Pure power:
Cardan shaft in WANGEN pumps

Maximum Variety

Maximum variety means:

- Various construction and rotor/stator sizes result in more than 100 models. Depending on the pump's size, the delivery rate ranges from 88.06 gmp to 660.4 gmp.
- A large variety of designs and materials for casings, rotors, stators, seals, and joints ensure that the pump can perfectly adapt to the medium.
- Our broad range of flange connections and drive units are ideal to find the best solution for your installation and available space.

We would be happy to develop a solution for your specific design.

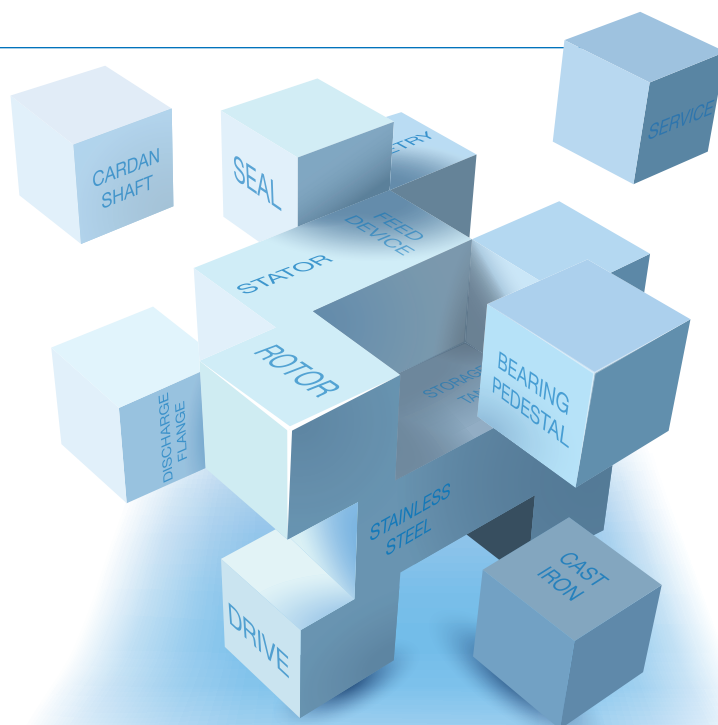

Benefits

Low Life-Cycle Costs

When purchasing a pump, we recommend that you carefully consider the operating costs as well as the costs for the initial purchase. Maintenance costs, production downtimes, and energy costs make up a considerable share of the total costs over the life-cycle of a pump.

Our philosophy is to keep the total costs of the entire pump life-cycle as low as possible by reducing needed maintenance to a minimum. This is possible due to our robust pump construction, the use of high quality wearing parts, and a wear-resistant design of the pumps.

Every avoided breakdown saves you expenses for spare parts, maintenance work, and production downtime. This ultimately results in saving money, but also reduces stress due to a smoother operating process.

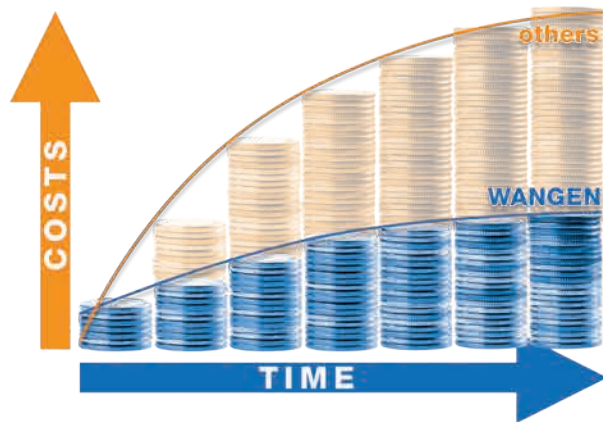

Easy Maintenance

In order to ensure a high level of system availability, many customers wish to maintain their pumps themselves. Therefore, our pumps have large inspection openings as a standard design. This enables easy cleaning of the pump, such as removing fibers and other foreign objects. It is also easy to switch the rotor and shaft seal due to the accessibility of the bearing pedestal. This makes it easier for you to carry out the necessary maintenance work yourself.



Technical Data

Models and Materials

There is a large selection of parts available for the design of our standard suction pump. We provide economical and optimized pumping solutions that are customized for your industry and operating conditions.

- Housing, pressure and suction flange: Grey cast iron, construction steel 1.0038, galvanized
- Joints: stainless steel cardan joints, optionally with sleeve
- Seals: Drive seals
- Rotor: Hardened tool steel, stainless steel 1.4301 (A304), stainless steel 1.4571 (A314Ti), both available with chromium or chromium carbide coating
- Stators: diverse NBR materials, FPM, silicon, EPDM
- Rotors and stators in up to 5 pressure classes and available as S-geometric forms.
- Drive: External via shaft (tractor etc.)

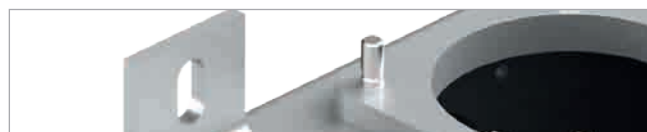

Technical data

Options and Accessories

We offer a large selection of accessories, which are perfectly matched to our product range, providing the ideal complement or adaptation to your individual requirements and allowing you to create your own customized solutions. If you need a special solution, we would be happy to assist you.

In order to increase the safety and flexibility, additional WANGEN pump accessories are available:

- Pneumatic overflow unit
- Hanging bar (GL-F)
- Bypass
- Optional equipment with multiple path slider
- and much more



Spare Parts

By using spare parts from WANGEN PUMPEN, we guarantee that the performance output of our pumps will be fully restored. With our decades of manufacturing experience, you will be able to profit from our first class quality as a manufacturer and, as a consequence, ensure the long service life of your pump.

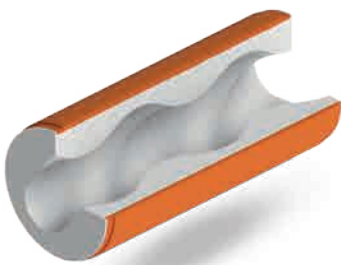

Technical Data

Performance Data GL-F

The WANGEN processing cavity pump of type GL-F is compactly built. It can be used to achieve high conveyance volumes and counter pressures. Attached to tank trailers, slurry tankers and umbilical hose systems, it is equally suited for mediums with different properties, such as fluid or slow-moving, mash-like, or loaded with solids.

The pump drive is provided by a power take-off or a drive shaft with a feather key. The integrated winding protection mechanism prevents fibers from winding around the joint and joint connections. The large inspection and cleaning openings on the suction housing allow an easy pump access.

Pump size	Maximum particle size (inch)	Flowrate (gpm) at 540 rpm	Maximum differential pressure (bar / psi)
50	3.425	264.2 – 704.5	16 / 174
65	4.724	352.2 – 2113	16 / 174

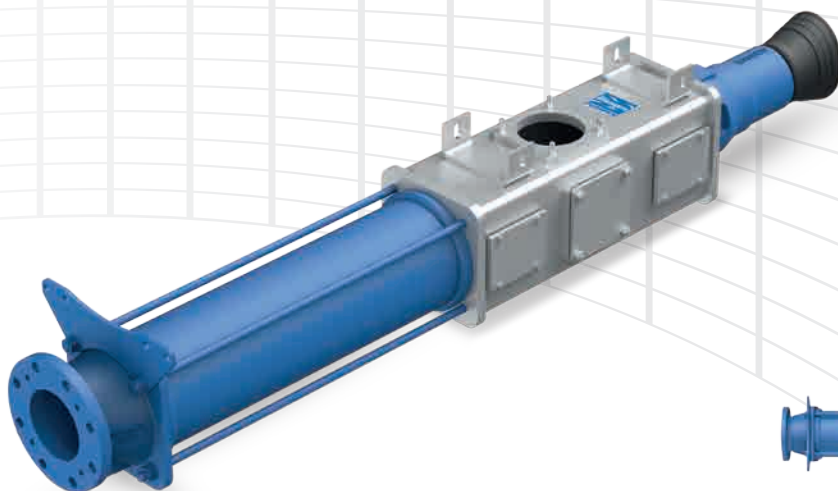

view from top



view from side

Technical Data

Performance Data A

Attached to slurry tankers, the WANGEN progressing cavity pump of type A is suitable for distributing water, slurry, and thick fluids, such as manure. The drive is implemented via a power take off profile that enables the pump to be easily coupled to the tanker. It has swivel pushers inside the suction

chamber that switch the pump from suction to pump mode. The pump is not sensitive to foreign objects and the deposition of foreign objects in the suction housing is not possible. In addition, hollow rotors ensure quiet operation.

Pump size	Maximum particle size (inch)	Flowrate (gpm) at 540 rpm	Maximum differential pressure (bar / psi)
80	2.48	264.2	16 / 174
90	2.80	396.3	16 / 174
100	3.11	528.3	8 / 116
110	3.43	704.5	8 / 116

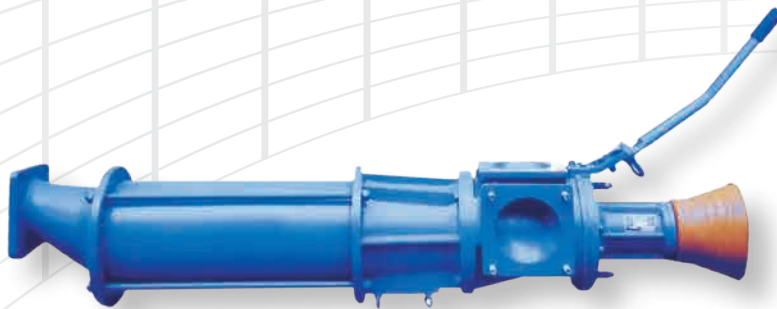

Technical Data

Performance Data GL-S

The WANGEN progressing cavity pump of type GL-S is particularly well suited to umbilical hose systems. Large distances and height differences are mastered easily. It may be used as a stationary pump or mobile pump, attached to a slurry tanker or chassis. The comprehensive range of pumps available make them a product for universal use.

They carry watery or thick mediums as well as mediums loaded with solids. WANGEN pumps of type GL-S are primarily used in agriculture.

Pump size	Maximum particle size (inch)	Flowrate (gpm) at 540 rpm	Maximum differential pressure (bar / psi)
50	3.425	132.1 – 528.3	16 / 174





Quality and Environmentally committed

WANGEN PUMPEN is ISO 9001:2008 and ISO 14001:2004 certified.



Represented by:

KGGO Group Ltd.

www.kgogroup.com

"The Benefit of Experience"

1200 Speers Rd., Unit 52 | Oakville | Ontario | L6L 2X4 | Canada 
Tel: 905.847.1544 | Fax: 905.847.1699 | info@kgogroup.com

