

FIBERGLASS REINFORCED PLASTIC VESSELS

OPERATIONS & MAINTENANCE MANUAL NO. 502



ISO 9001 REGISTERED

MISSION STATEMENT

Plas-Tanks Mission is to Provide Solutions to Material Storage or Processing Problems through the Effective Fabrication of Pollution-Free Reinforced Plastic Products.

We Espouse Conformance to Stated Requirements, Continuous Improvement, and Partnership with All Who Have a Stake in Our Success.

TABLE OF CONTENTS

GENERAL	1
STATEMENT OF WARRANTY	2-3
INSPECTION INSTRUCTIONS.....	4
UNLOADING INSTRUCTIONS WITH LIFTING CHANNELS.....	5
INSTALLATION INSTRUCTION 502 FOR FLAT BOTTOM TANKS	6-7
TIE DOWN LUG	8
PRE-STARTUP INSPECTION INSTRUCTIONS	9
OPERATION INSTRUCTIONS	10
MAINTENANCE INSTRUCTIONS.....	11
CLEANING INSTRUCTIONS	12
PAINTING INSTRUCTIONS	13
PLASTA THERM™.....	14-15
LADDER.....	16

INSERTS

ENGINEERING DRAWINGS

Note: Your vessel may not require all listed parts. Please refer to the packing list and Engineering Drawing for specific items on your vessel.

GENERAL

All atmospheric tanks must be vented directly to the atmosphere without any obstructions. The vent pipe shall be independent of all other process and vent piping. **DO NOT INTERCONNECT VENT PIPE TO MULTIPLE TANKS.**

All non-atmospheric tanks must each have an overpressure protection device that is sized based on the tank design conditions, for both positive and negative pressure.

The tanks have been designed in accordance with applicable ASTM, ANSI and ASME standards, see Engineering drawings for reference.

If questions arise that pertain to the vessel(s) or the information contained in this manual, contact:

1

STATEMENT OF WARRANTY

1. **WARRANTY**

- A. Except as provided in Sections 1 (B) and 1 (C) below, the Corporation warrants (1) that the goods manufactured by it shall conform to the standards and specifications set forth in its current catalogue and/or any construction drawings approved by the Buyer, (2) that the goods shall be free from defects in material where said material was actually manufactured by the Corporation, (3) that the goods shall be free from defects in workmanship, (4) that the goods shall be made with the materials as specified, and (5) that the goods shall pass without objection in the trade under the contract description. **THIS WARRANTY IS EXPRESSLY IN LIEU OF ALL OTHER WARRANTIES EXPRESSED OR IMPLIED INCLUDING IMPLIED WARRANTIES OF MERCHANTABILITY AND EXPRESSED OR IMPLIED WARRANTIES OF FITNESS FOR A PARTICULAR PURPOSE.**

- B. Where the Buyer has furnished the Corporation with plans and specifications for the goods to be purchased by the Buyer hereunder, the Corporation acknowledges receipt of the same and warrants that the goods manufactured by it as amended by any written agreement between the Corporation and Buyer prior to delivery, shall meet the specifications and plans furnished to it by the Buyer and shall be free from defects in workmanship. **THIS WARRANTY IS EXPRESSLY IN LIEU OF ALL OTHER WARRANTIES EXPRESSED OR IMPLIED INCLUDING IMPLIED WARRANTIES OF MERCHANTABILITY AND EXPRESSED OR IMPLIED WARRANTIES OF FITNESS FOR A PARTICULAR PURPOSE.**

- C. The Corporation **MAKES NO WARRANTIES, EXPRESSED OR IMPLIED**

INCLUDING IMPLIED WARRANTIES OF MERCHANTABILITY AND EXPRESSED OR IMPLIED WARRANTIES OF FITNESS FOR A PARTICULAR PURPOSE as to any goods or materials used in any goods sold hereunder, which goods or materials were not actually manufactured by the Corporation. The Corporation assumes no responsibility for goods manufactured by others and such materials carry only the warranty of their original manufacture.

2. REPLACEMENT

The Corporation agrees that in the event any of the goods sold hereunder shall fail to comply with the provisions of the appropriate warranty, it shall repair or replace the goods, or any part thereof of its own manufacture, which under normal installation, use and service disclosed such defect, provided that the goods are intact for examination by the Corporation and it has received written notice of the specific defect within three (3) years from the date of invoice, and provided that such examination discloses in the judgment of the Corporation that the goods are thus defective. The warranty does not extend to any goods which have been subject to misuse, neglect, accident, incorrect wiring, improper installation, or to goods used in violation of instructions furnished by the Corporation, or extend to goods which have been repaired or altered by anyone other than the Corporation's authorized personnel.

2

3. LIMITATION OF LIABILITY

In the event of a breach or repudiation of this contract or any of its provisions by the Corporation, the Buyer shall not be entitled to recover incidental or consequential damages including those arising upon breach of IMPLIED WARRANTY OF MERCHANTABILITY OR FITNESS FOR A PARTICULAR PURPOSE OR ANY LOSSES, COSTS, EXPENSES, LIABILITIES AND DAMAGES (INCLUDING, BUT NOT LIMITED TO, LOSS OF USE OF PROFITS, EXPENSES OR OPERATION, DOWNTIME, RECONSTRUCTION OF WORK, DAMAGES TO PROPERTY, ALL LIABILITIES OF BUYER TO ITS CUSTOMERS OR THIRD PERSONS, AND ALL OTHER SPECIAL OR CONSEQUENTIAL DAMAGES) WHETHER DIRECT OR INDIRECT, AND WHETHER OR NOT RESULTING FROM OR CONTRIBUTED TO BY THE DEFAULT OR NEGLIGENCE OF THE CORPORATION, ITS AGENTS, EMPLOYEES, OR SUBCONTRACTORS WHICH MIGHT BE CLAIMED AS THE RESULT OF THE USE OR FAILURE OF THE GOODS DELIVERED HEREUNDER. The Corporation's liability on its warranty shall in no event exceed its cost of correcting the defect in the goods sold hereunder or replacing the same with non-defective goods.

3

INSPECTION INSTRUCTIONS

When your Plas-Tanks product left our plant, it was carefully inspected to be certain that it complied with our company standards. Occasionally, however, damage can occur while in transit. Therefore, we ask that you carefully inspect the product for damage, particularly as follows:

1. Look over the exterior of the product for scars, scratches and abrasions.
2. Check external appurtenances such as nozzles and clips to be certain that none are broken, chipped or otherwise damaged.
3. Inspect the inside of the vessel very carefully to be certain that the liner is smooth and intact. Interior damage will usually take place in the form of a star craze, i.e., radial cracks originating from a central point.
4. Verify that all accessories, such as fasteners and gaskets, are present and undamaged.

If any discrepancies exist, be sure to make a notification on the Bill of Lading. Following this action, please notify Plas-Tanks so that we can arrange for inspection and repair, if necessary.

When a Plas-Tanks vessel arrives on a truck, please inspect the vessel carefully both inside and outside for possible damage incurred during shipment. This inspection should take place prior to unloading or handling the vessel. Should damage exist, please make a notation to this respect on the bill of lading and notify your Plas-Tanks representative or the home office immediately. Unless the damage is severe, it is satisfactory to remove the vessel from the trailer but do not set the vessel up vertically, as damaged areas are much more difficult to reach on an erected vessel.

When ordering a crane, inform the rigger of the weight of the vessel and of the distance the vessel is to be moved by a stationary crane. Do not select the capacity of the crane merely in accordance with the weight of the vessel, as the crane is rated with its boom in a near vertical position and the rating reduces as the boom moves toward a horizontal position. The crane should have either a three-way sling or three chokers. The chokers should be at least the diameter of the vessel in length and should be of sufficient tensile strength to accommodate the load.

The vessel will arrive with three lifting channels equally spaced at the top (front) of the vessel with one of the three located at the twelve o'clock position. There will be a fourth channel or tie down lug at the bottom (rear) of the vessel also at the twelve o'clock position. (See figure A) To unload the vessel, attach the slings or chokers of the load line to channels A, B and C with the whip line attached to channel or tie down lug D. To remove the vessel, lift it by both the load line and the whip line maintaining the horizontal position. (See figure B) Do not attempt to move the vessel to a vertical position at this point, as the bottom rear of the vessel will be pulled forward along the bottom of the trailer. It is also possible that the rear of the vessel would be pushed into the drop of the trailer. After the vessel has been elevated sufficiently to clear the trailer, move it laterally several feet. The vessel may now be carefully brought into a vertical position by reducing the load line and slackening the whip line. As the vessel becomes vertical, channel A will assume an equal load to channels B and C, with channel or tie down lug D becoming ineffective. The whip line can be disconnected at this point. The vessel can now be moved to set upon the pad. (See "Installation Instructions".)

Most instances of damages to a fiberglass vessel occur during rigging operations and result from improper or careless handling or from failure to follow the installation instructions. We recommend that you and the riggers' personnel familiarize yourselves with these instructions and that you exercise extreme care during handling. Please inspect the vessel again after placement for internal and external damage.



FIGURE A

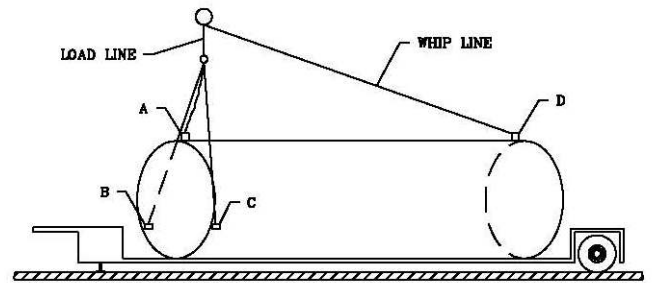

FIGURE B

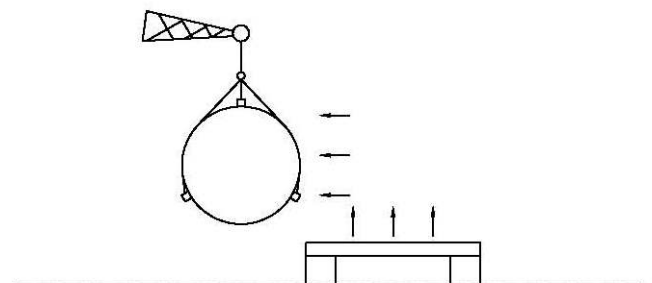

FIGURE C

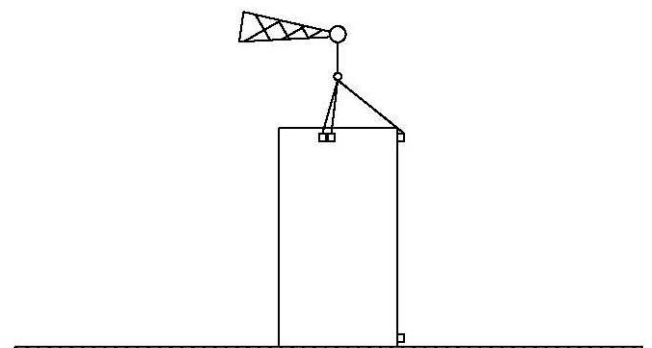

FIGURE D

Filling a vertical tank obviously places stress on the sidewall, causing it to try to move outward. This stress is manifested to the greatest extent at the knuckle radius - the point of junction between the bottom and the straight shell. To assure the maximum possible life of the tank, the Plas-Tanks' design includes a generous amount of reinforcement in the knuckle area. With any fiberglass tank, the knuckle reinforcement will extend below the rest of the tank bottom causing an empty tank to rest on its extremities only. When the tank is filled, its bottom is pushed downward, causing stresses in the knuckle. Emptying the tank allows the bottom to rise upward in the center; continuous cycling results in continuous flexing at the knuckle.

The support base for flat-bottomed vertical vessels should provide full and uniform support over the entire bottom area. The support base should be properly designed to prevent settling or deflection under maximum design loads. The support base surface must be nonporous and free of cracks, depressions and vertical projections. Reinforced concrete, trowel finished to American Concrete Institute Specifications (ACI-301-72, Section 11.7.3, "Trowel Finish") is often used as a support base. Each flat bottom unit must be set on a cushioning pad to minimize stresses caused by seams, shrinking distortion and/or support base irregularities. Where irregularities are less than ½ inch (12.7mm) in depth, use layers of 30 lb. roofing felt (see the illustration on the next page for quantity and size required). Where irregularities in the surface of the support base are greater than ½ inch (12.7mm) in depth, an asphalt type of paving mastic can be troweled into these areas and pressed or tamped to provide a reasonably hard, flat, and level surface. Time should be allowed for the mastic to harden (4 hours minimum) before the first layer of roofing felt is applied. A suitable elastomer sheet material of proper environmental resistance may be substituted for the roofing felt.

Important, if the tank bottom was fabricated with a core material and the bottom has concavity more than ½" in depth, a wet concrete grout mix without rocks should be used instead of the roofing felt illustration on the following page. Pyramid the wet grout mix from a thickness of 3" at the center, to a thickness of ½" toward the perimeter of the vessel.

When providing for openings in the foundation for bottom projecting fittings, always keep the unsupported area around the fittings to a minimum, and round all corners of the foundation cutout. There are several other very important procedures one should follow in order to achieve a successful and long lasting installation. They are as follows:

1. All tie down lugs **MUST** be used to secure the tank to the pad using a double nut configuration on the anchor bolts. There will be a gap between the bottom of the tie down lugs and the tank bottom. Place a shim beneath each lug on the concrete foundation before tightening the nuts onto the anchor bolt. Hand tighten the bottom nut then turn an additional ¼ turn. Tighten top nut to lock in place.
Important, the tank should be filled with contents prior to installing shims to allow for possible expansion of the tank knuckle, caused by fluid head pressure.
2. Valves and piping attached to the tank nozzles must be independently supported.
3. Flanged nozzles must be gasketed using full-face gaskets 40 to 60 durometer with a minimum thickness of .125".
4. Raised face flanges shall not be used to bolt-up to tank nozzles.
5. All atmospheric tanks must be vented directly to the atmosphere without any obstructions. The vent pipe shall be independent of all other process and vent piping. **DO NOT INTERCONNECT VENT PIPE TO MULTIPLE TANKS.** All non-atmospheric tanks must each have an overpressure protection device that is sized based on the tank design conditions, for both positive and negative pressure.

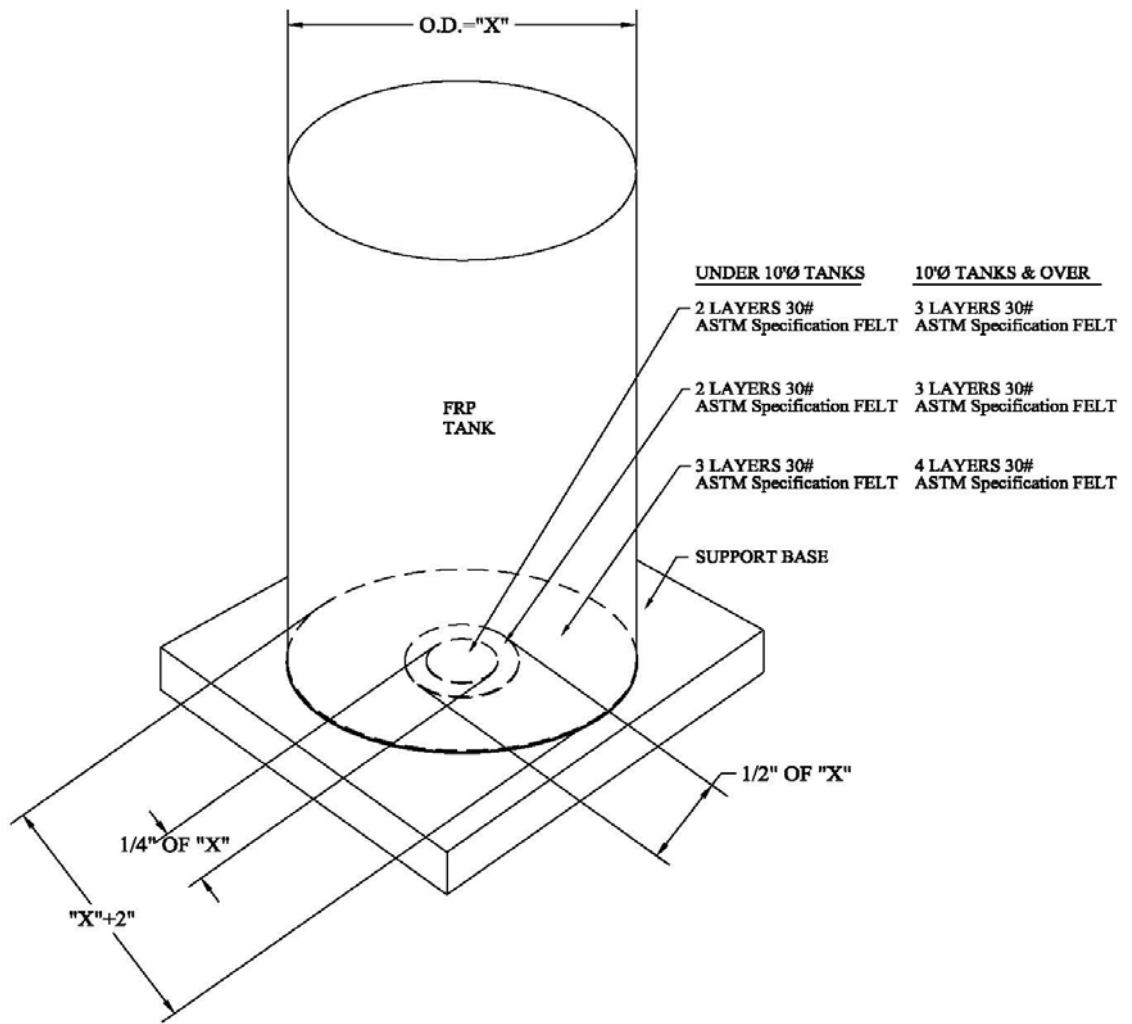

TIE DOWN LUG

Due to the possible shrinkage of fiberglass, it is difficult to maintain exact dimensions for the locations of the tie down lug boltholes. Therefore, Plas-Tanks recommends that boltholes in the foundation be drilled after the vessels are set. If studs must be set when the foundation is being poured, the preferable method of tie down is to use one anchor bolt beyond the edge of each tie down lug (contact the factory for anchor bolt circle Ø). The hold down angle illustrated below is then placed on the top of the lug.

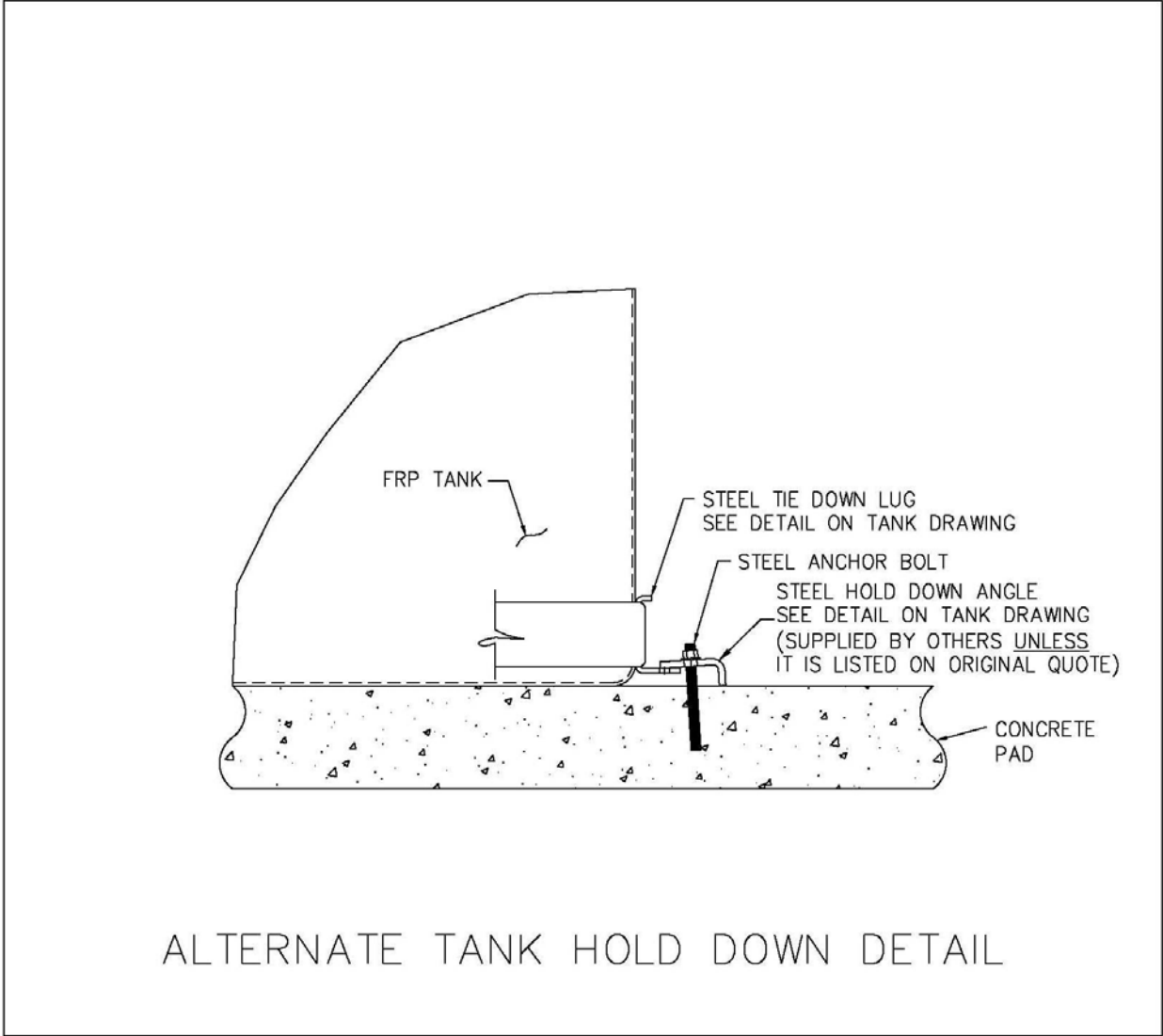

PRE-STARTUP INSPECTION INSTRUCTIONS

The first step to insure a long and trouble free service life begins with a pre-startup inspection immediately following installation. Remember that fiberglass vessels unlike steel vessels are more susceptible to damage from rough handling. This damage will usually manifest itself in the form of cracks or crazing.

1. Conduct an inspection from inside the vessel. For a clear view of the laminate, it is recommended that someone assist your inspection outside the vessel directing a light through the area being inspected. This procedure will insure the detection of the smallest of cracks.
2. Inspect the bottom of the vessel to insure that it has been properly supported. This can be accomplished by walking on the inside of the vessel. If the bottom flexes, it has not been uniformly supported. This condition left uncorrected could cause damage to the bottom.
3. Inspect tie down lugs for proper installation. All tie down lugs must be securely fastened to the concrete pad. The gap between the bottom of the lug and the bottom of the vessel should have been shimmed. An unsecured lug can cause damage to the bottom knuckle area of the vessel.
4. Attachments of all nozzles and fittings must be independently supported. Flanged nozzles to pipe flange connections must be made with full-face gaskets and bolts of the proper size. Inspect around the boltholes on flanged nozzles for cracks caused by over torquing or the use of improper gaskets. Inspect the neck of the flanged nozzle and threaded fittings for cracks caused by poor support or misaligned piping.
5. Plas-Tanks vessels are designed to operate at atmospheric pressure and were supplied with a vent nozzle. The piping from this vent nozzle must always remain open to the atmosphere. Inspect the piping running from the nozzle to insure that it is the same size or larger than the nozzle and that it is vented directly to the atmosphere, not interconnected with other vent piping.

OPERATION INSTRUCTIONS

When placing a fiberglass vessel into service, there are four items of concern. The following is a listing of those items and a brief explanation of their importance.

1. The vessel(s) were designed for the storage of a specific service. Do not store or process any other chemical without first consulting Plas-Tanks. **NOTE:** Not all fiberglass resins are compatible with all chemicals.
2. Plas-Tanks vessel(s) are designed for atmospheric pressure or various amounts of positive or negative pressure. Most vessels are supplied with a vent. This vent must always remain open and cannot be reduced in size under any circumstance. **NOTE:** Small amounts of pressure or vacuum can cause the complete failure of a vessel designed for atmospheric pressure.
3. The vessel(s) have been designed for a specific operating temperature. Do not operate above the design temperature as vessel failure may result. **NOTE:** Do not allow stored material to freeze.
4. Often, the chemicals to be stored are delivered by a vehicle that uses air pressure to transport the product to the vessel. This process is called "Air Loading". If the CFM introduced to the vessel combined with CFM of air displaced by the product exceeds the CFM capacity of the vent, damage will result.

MAINTENANCE INSTRUCTIONS

If installed properly, your Plas-Tanks fiberglass reinforced plastic vessel(s) will provide years of trouble free service. Because of the high corrosion resistance of fiberglass reinforced plastic vessel(s) and the fact that there are no moving parts on a vessel, the maintenance requirements are almost non-existent. However, there are a few things that need periodic maintenance.

1. Because the exterior of the vessel(s) may not have the same corrosion resistance as the inside of the vessel(s), any chemical spills must be removed immediately. **NOTE:** Never clean a vessel(s) with an abrasive-cleaning compound. In most cases, water and a mild liquid detergent will suffice.
2. All piping and valves must be independently supported. Check the pipe hangers and supports to insure that no loads have been applied to the vessel(s) nozzles or fittings due to settling of the foundation or vessel(s) pads.
3. If for some reason your vessel(s) is damaged in transit, storage, during installation, or after it is placed in service, and the damage appears to be minor, you can affect a repair if you understand the basic fiberglass repair procedures and have on hand the proper fiberglass repair kit. **NOTE:** Minor damage is classified as scratches, small star crazes and cracks that do not extend through the entire wall top or bottom, and support clips that have been broken. A qualified fiberglass laminator with a minimum of 5 years experience should repair any other damage.

CLEANING INSTRUCTIONS

The first step in cleaning a vessel should be to wash all dust or dirt from the surface. If there is sludge in the bottom of the vessel, remove it with a plastic shovel. Never use anything to clean a vessel that could scratch the liner or cut into the resin rich surface.

After all of the dirt has been removed wash the inner and outer surfaces with a mild soap and water using a soft bristled brush to apply it.

Never use solvents to clean a Fiberglass Vessel

After the vessel has been cleaned allow it to air dry prior to placing it back in service.

PAINING INSTRUCTIONS

To paint a fiberglass vessel you must first prepare the surface. There are two methods; one, sand the outer surface with a medium grit sanding disc and two, sand blasting. Regardless of which method you use, care must be taken not to remove too much material, 6 to 8 mils maximum.

After prepping the surface, wash the outside of the vessel as described on page 12 – vessel cleaning. Allow the vessel to air dry.

After the vessel has dried, spray or brush on good epoxy paint formulated for outside use. Follow any special instructions provided by the paint company.

PLASTA-THERM™

The Plasta-Therm™ heating element consists of a fine-gauge, stranded nickel chrome alloy wire in braided fiberglass. The heat tapes are installed directly in the tank bottom allowing the heat to rise naturally. The Plasta-Therm™ element thus becomes an integral part of the vessel itself. Protected by its own fiberglass braiding and by the fiberglass of the vessel on both sides of the tape, the elements are almost damage-proof. A sensing element is positioned between the tank outer wall and foam insulation where it senses the temperature of the tank contents. The sensing element and the heating elements are connected to a control box that is mounted on the vessel wall.

The Plasta-Therm™ System comes completely wired and is designed for 120V or 240V. Check the drawing for voltage designation. A set of wiring instructions is on the following page.

MODEL 2E848
TEMPERATURE CONTROL BOX

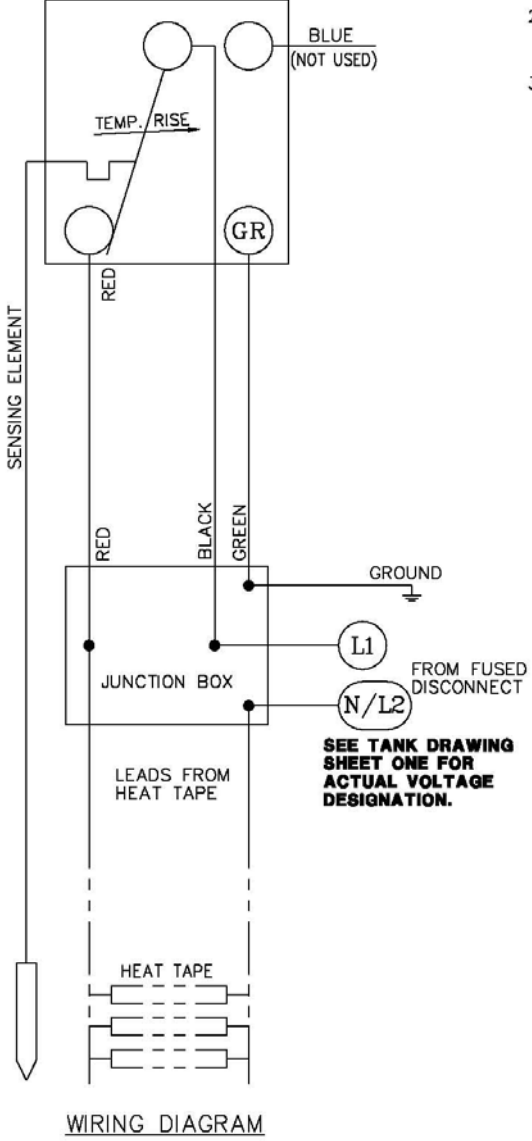

SEE TANK DRAWING SHEET ONE FOR ACTUAL VOLTAGE DESIGNATION.

- NOTES**
- 1.) HEATING SYSTEM IS PRE-WIRED AT FACTORY. THE ONLY CUSTOMER WIRING REQUIRED IS TO RUN LINE AND GROUND WIRES TO THE JUNCTION BOX FROM A FUSED DISCONNECT.
 - 2.) ENCLOSURE MEETS NEMA CLASS 4X REQUIREMENT WHEN USED WITH APPROPRIATE WATERTIGHT CONDUIT CONNECTION.
 - 3.) ELECTRICAL RATING: 25 AMPS FOR RESISTIVE LOAD. **SEE TANK DRAWING FOR ACTUAL VOLTAGE.**

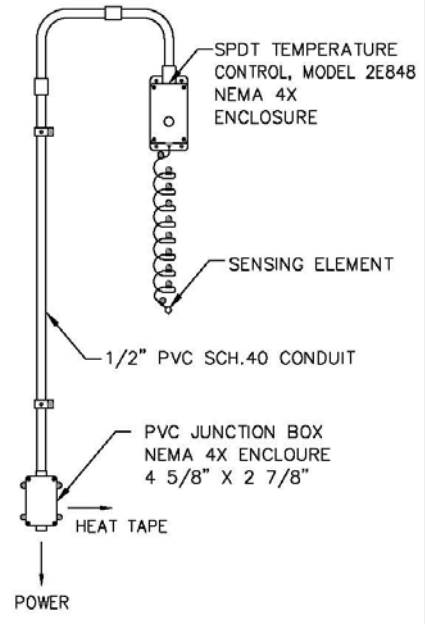

PLASTA-THERM HEATING SYSTEM
CONTROL

NO.	DATE	BY	CK	REVISION
1	7/15/04	X.G.	J.P.	UPDATED NOTE #3. ADDED VOLTAGE NOTE IN WIRING DIAGRAM.



Plas-Tanks
INDUSTRIES, INC.
20 Stansden Drive
Hamilton, Ohio 45015 513-943-3800

DRAWN: X.CAI/8-2-02	CHECKED: J. PUTHOFF 7/15/04
PART NO.: PT-HT10010	SHEET 1 OF 1

LADDER

There are three types of ladders furnished for our vessel: fiberglass, aluminum, or galvanized steel. Although they are manufactured using three different types of materials, they are installed the same way.

Based on the height of the vessel, it will have between three and six sets of fiberglass ladder clips mounted on the vessel wall. These clips correspond to pre-drilled holes in the ladder rails. If you don't have the equipment to set the ladder upright available at your plant, you may want to install the ladder during the unloading of the vessel.

Erect the ladder on the side of the vessel between the mounting clips. The clips have been designed to allow a 1/8" clearance between each clip and the ladder. Because the ladder was installed at our plant and mounting holes drilled, you may need to raise the ladder slightly so that the clips are aligned. The ladder's weight **must** be supported off the vessel pad. The ladder is designed to be above the vessel bottom. At this time, you need to shim under the footpads so that the weight will rest on the concrete pad and not on the vessel clips. Be extra careful that the ladder does not swing away from the vessel wall. It may be a good idea to have someone present.