

INSTRUCTION MANUAL

Rev 01.04.00

PERIFLO PERISTALTIC PUMP MODELS: RBT60

EQUIPMENT IDENTIFICATION RECORD

PUMP MODEL NO: _____ PUMP S/N: _____

CUSTOMER: _____ ORDER NO: _____

JOB NO: _____ TAG NO: _____

HOSE MATERIAL: _____ MOUNTING POSITION: _____

CONFIGURATION:

- FIXED SPEED MOTOR GEAR REDUCER
- VARIABLE SPEED MOTOR GEAR REDUCER
- VARIABLE SPEED MOTOR + VFD

REDUCER MANUFACTURER: _____ GEAR RATIO: _____

REDUCER SERIAL NUMBER: _____ REDUCER MODEL: _____

MOTOR MANUFACTURER: _____ HORSEPOWER: _____

SPEED: _____ RPM VOLTS/PH/CY: _____ ENCLOSURE: _____

SPECIAL RATINGS: _____

LEAK DETECTOR: TYPE _____ MODEL _____

ACCESSORIES: _____

FLUID TO BE PUMPED: _____ OPERATING TEMPERATURE: _____ °F

DESIGN FLOW RATE: MIN _____ MAX _____

VISCOSITY (@PUMPING TEMPERATURE): _____ CPS

SOLIDS: - _____ % BY WT. PARTICLE SIZE: _____

DESIGN DISCHARGE PRESSURE: _____ PSIG MAX DESIGN PRESSURE: _____ PSIG

MINIMUM WORKING SPEED: _____ RPM MAXIMUM WORKING SPEED: _____ RPM

INSTRUCTION MANUAL

Model: _____ Serial Number: _____

INDUSTRIAL PERISTALTIC PUMP MODELS RBT60

This manual forms an integral part of the pump and must accompany it until its demolition. The series RBT peristaltic pump is a machine destined to work in industrial areas and as such the instruction manual must form part of the legislative dispositions and the applicable technical standards and does not substitute any installation standard or eventual additional standard.

GENERAL SAFETY WARNING

Pumps are machines that can present dangers due to their operating pressure and containing numerous moving parts.

- Improper use
- Removing the protections and/or disconnecting the protection device
- The lack of inspections and maintenance

CAN CAUSE SERIOUS DAMAGE OR INJURY

The person in charge of safety should therefore guarantee that:

- The pump is transported, installed, put in service, used, maintained and repaired by qualified personnel who should possess:

- Specific training and sufficient experience.
- Knowledge of the technical standards and applicable laws.
- Knowledge of the general national and local safety standards and also of installation.

Any work carried out on the electrical part of the pump should be authorized by the person responsible for safety. Given that the pump is destined to form part of an installation, it is the responsibility of whoever supervises the installation to guarantee absolute safety, adopting the necessary measures of additional protection.

INDEX

	Page number
• Identification Record	01
• Cover	02
• Index	03
• Transport, storage & movement	04
• General safety standards	05
• General description	07
• Installation	08
• Checks before start-up	09
• Maintenance	11
• Removing the hose – Disassembly	12
• Installing the hose – Assembly	13
• Problems, causes and solutions	14
• Diagram of components parts	15
• Spare parts code	17
• Warranty	18

TRANSPORT, STORAGE AND MOVEMENT

TRANSPORT

- The pump is protected by packaging with a rigid bottom (pallet) and a cardboard covering.
- The packaging materials are recyclable.
- During transportation, the pump is in a resting position (the hose is not compressed)

STORAGE

- The pump should be in a resting position. (The hose should not be compressed).
- Avoid areas open to inclement weather or excessive humidity.
- For storage periods of longer than 60 days, protect the coupling surfaces (clamps, reducers, motors) with adequate anti-oxidant products.
- Pipe spares should be stored in a dry place away from direct light.

MOVEMENT

- To lift the pumps, use the hooks positioned for this purpose with adequate machinery. Check the weight of the equipment before its manipulation or movement.

SAFETY STANDARDS



- Instructions in this manual that may compromise safety standards are identified by this symbol



- Instructions in this manual that may compromise electrical safety are identified by this symbol.

WARNING!

- Instructions in this manual that may compromise the proper operation of the pump are identified with this symbol.



Do not start the pump without first installing the front cover and the acrylic inspection covers.



For any maintenance of the equipment, especially via the acrylic inspection covers, make certain that the pump is stopped and the electrical supply disconnected.



Changing the hose should be done with the front cover and inspection covers correctly fixed in place.

WARNING!

Do not exceed the nominal pressure, speed or temperature of the pump, or use the pump for applications other than originally planned without first consulting the manufacturer.

CHARACTERISTICS FOR CONTINUOUS SERVICE

Hose Material	Temp.Min.(°F)	Temp.Max.(°F)	Temp.Max.(°F) lubricant	Temp.Min.(°F) environment	Pressure Max. (PSIG)
Natural Rubber	-4	176	176	-40	220
Buna	14	176	176	-40	220
EPDM	14	176	176	-40	220

WARNING!

Do not start the pump without it being properly secured to the floor.

Do not attempt to carry out any maintenance operations or dismantle the pump without first making sure that the suction and discharge pipes are not under pressure, and are empty or isolated by proper valving.



The start system of the motor should be provided with a direction switch, stop-go button and emergency stop button (together with the pump), in such a way that the pump can be operated or the hose changed with total safety.



Do not attempt to carry out any maintenance operations or dismantle the pump without insuring proper isolation of the electrical motor.

In the case of the hose becoming stuck during removal or installation it is necessary to reverse the direction of the pump, relubricate, and then repeat the operation.



Peristaltic pumps are positive displacement devices capable of generating high pressures. To prevent a possible overload of pressure, due to for example, the accidental closure of a valve. It is advisable to fit a safety device such as: a safety relief valve or other pressure limiting device in the discharge piping.



Check the direction of rotation of the pump, as it is reversible it could generate pressure in the suction and compromise the safety of the installation. The circulation of the fluid should be in the same direction as the turning direction of the pump as seen from the inspection plate situated on the front cover.



The durability of the hose may vary due to operating conditions, so the possibility of a rupture and subsequent leakage of fluid should be anticipated. The (optional) hose leakage detection probe can be interlocked to stop the pump and/or actuate an automatic isolation valve and/or and alarm.

GENERAL DESCRIPTION

PERISTALTIC PUMP

- **Construction of the pump.**

As shown in the figure below, the pump unit is a very simple design, robust and with very few moving parts.

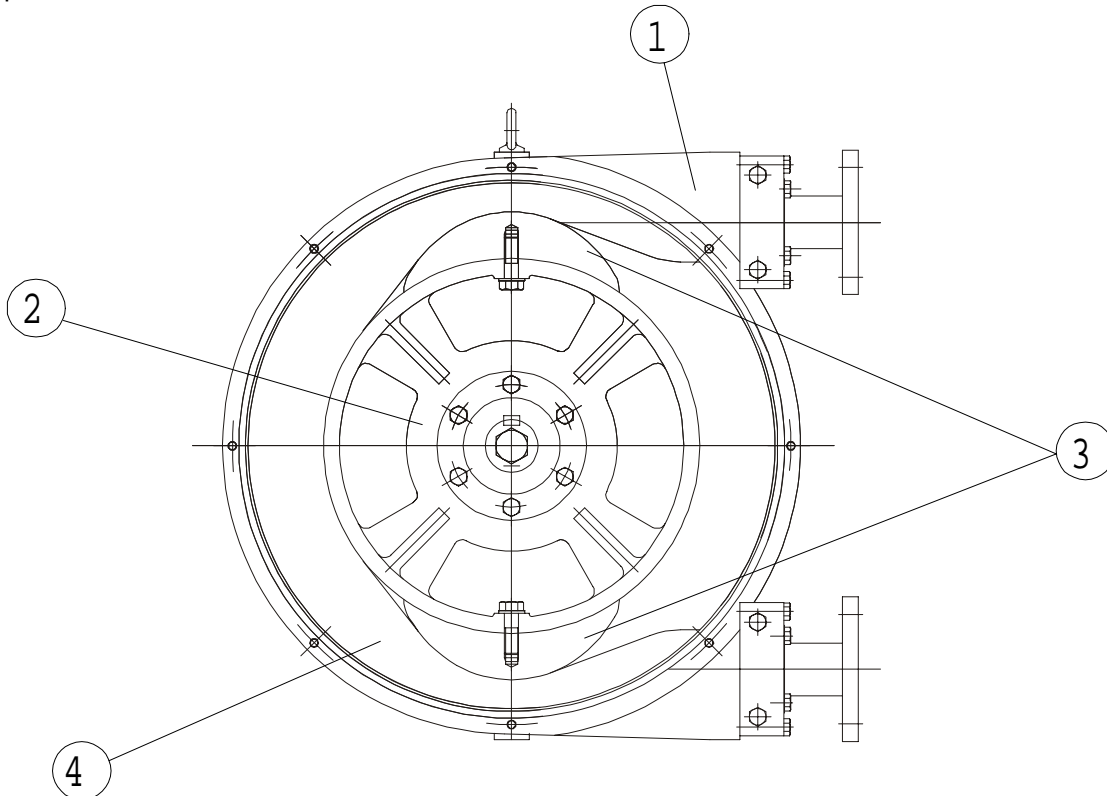

The outer casing (item 1) terminates with 150# ANSI flanged connections. Inside the casing are the rotor (item 2) complete with two rotor shoes (items 3). As the rotor rotates, the shoes compress the reinforced hose (item 4) generating a pumping action. A change in the direction of rotation will result in a change in direction of the pumped fluid.

INSTALLATION

- Installation should normally be made in a well ventilated area away from heat sources. If the pump is installed outside, it should be provided with a cover to protect it from sunlight and inclement weather.
- The positioning of the pump should allow easy access for all kinds of maintenance operations. In general, and to facilitate the changing of the hose, it is advisable to use easily removed connectors and, once free, there should be a minimum space of approximately 36 inches and 40 inches for Models 25 and 32 respectively.

Piping - Correct Installation

Removable Sections: Removable piping sections should be provided at the suction and/or the discharge to facilitate the easy removal and/or installation of the hose.

Suction:

- The pump should be as near as possible to the supply of liquid so that the suction pipe is as short and straight as possible. The suction pipe should be perfectly airtight and made of suitable material so that it does not collapse due to internal vacuum.
 - The minimum diameter should be similar to that of the hose element.
 - With viscous fluids a larger diameter is recommended.
(Consult manufacturer or distributor).
 - The pump has automatic suction and does not need an inlet valve.
- The pump is reversible, so the suction and discharge connections are interchangeable.
(The pump is normally piped in a manner that best adapts to the physical installation).
- It is recommended to use a flexible connection between the fixed piping and the pump in order to reduce the transmission of vibration to the piping.

Discharge:

- To reduce power requirements, use the straightest and shortest piping possible. The diameter should be the same as the nominal diameter of the pump, excepting precise calculations of pipe and system losses.
 - With viscous fluids a larger diameter is needed.
(Consult the manufacturer or distributor).
- Connecting the fixed piping to the pump with a length of flexible pipe facilitates maintenance and avoids vibrations and loads on the pump. Fix the piping firmly.
- The discharge will pulse: To reduce pulsation, it is advisable to install adequate pulsation dampening equipment in the discharge piping. (Contact PeriFlo for details.)

CHECKS BEFORE SWITCHING ON THE PUMP

- Check that the pumping equipment has not suffered any damage during transportation or storage, any damage should be notified to the supplier immediately.
- Check that the supply voltage is suitable for the motor.
- Make sure that the hose is suitable for the fluid to be pumped and that it will not be chemically affected, check also that the temperature of the fluid does not exceed that recommended.

If the pump has come from long term storage; it will be necessary to install the second shoe and its corresponding shims (see corresponding table).

Do not run the pump without the pump body cover and the transparent inspection plates correctly positioned and fixed.

SHIMMING: Shims are metal plates designed to adjust clearances to achieve a correct compression/flattening of the hose. (item 7 of the component parts diagram page 17) Check that the number of shims is correct for the application (see the following shim tables).

Note: incorrect shimming can cause premature hose failure.

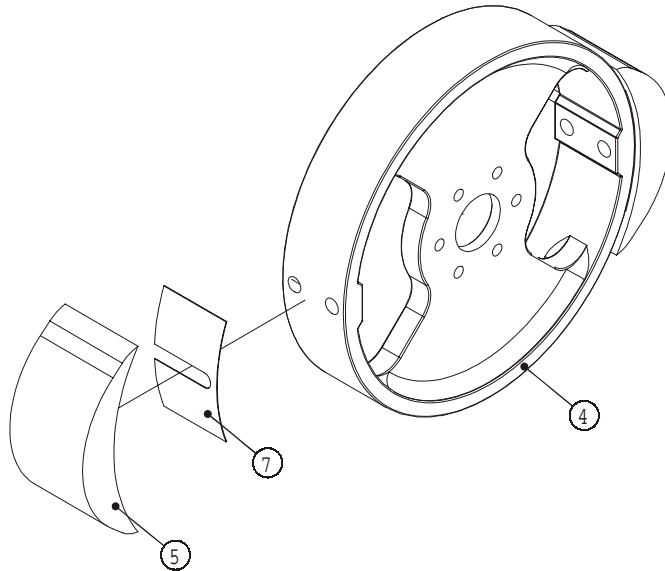

RBT60

RPM	0-19	20-39	40-59	60-79	80-99
PSIG					
7.5	3	2	2	2	1
35	3	3	3	2	2
75	4	3	3	3	3
110	4	4	4	3	3
150	5	4	4	4	--
185	5	5	5	4	--
220	6	5	5	--	--

- **Rotor.**

Check the clearance between the machined face of the rotor and the face of the front cover
RBT-25 = 11 mm. / RBT-32= 12 mm.

- **Lubrication - HOSELUBE**

Check that the level of the lubricant in the casing of the pump is correct.
(RBT-25 = 68 oz. ; RBT-32 = 102 oz.).

The specially formulated PERIFLO HOSELUBE lubricant can be obtained from PERIFLO or from the authorized distributor. The use of PERIFLO HOSELUBE lubricant ensures proper pump operation and longer hose life.

Check that the protectors of the moving parts are correctly assembled.

Check that the thermal protector corresponds with that of the values on the plate on the motor.

Check that the direction of rotation is the desired one. (rotation test).

Check that the optional electrical components are connected to the control panel and test that they function correctly.

Check that a proper pressure gauge is installed in the discharge. If the application involves a highly viscous fluid, it is recommended that a proper absolute-pressure gauge be installed in the suction.

Check in predicted working conditions that the values of flow, pressure and motor power correspond to the project.

MAINTENANCE

Any work carried out on the pump must be done when the pump is stationary and disconnected from the electrical supply.

Pump Lubrication

Check that the lubricant level is correct. The correct level is shown on the lower inspection cover installed on the front cover of the body of the pump. Add lubricant as necessary.

USE ONLY GENUINE PERIFLO HOSELUBE.

Drive Lubrication

Check that the lubricant level in the gear reducer and/or the variator are correct and carry out periodic changes of lubricant according to the maintenance manual.

FOLLOW THE LUBRICATION RECOMMENDATIONS OF THE DRIVE MANUFACTURER.

REMOVING THE HOSE - DISASSEMBLY

- Close suction and discharge valves to properly isolate the pump and prevent loss of the product.
- The outer body of the pump must be drained of all lubricating liquid, removing both the interior drain plug and the upper vent plug. The plugs are located on the rear part of the pump casing.
- Disconnect the suction and outlet piping.
- Disconnect suction and discharge flanges with the hose inserts (items 1 and 2) by removing the bolts (8). At this point the closing rings (item 5) can remain fixed to the ends of the hose. They can be easily separated by using a flat bladed screwdriver in the groove of the sealing ring to gently open it and then extract it from the hose. (NOTE THAT THE CLOSING RINGS SHOULD BE RETAINED FOR USE IN THE INSTALLATION OF THE NEW HOSE)

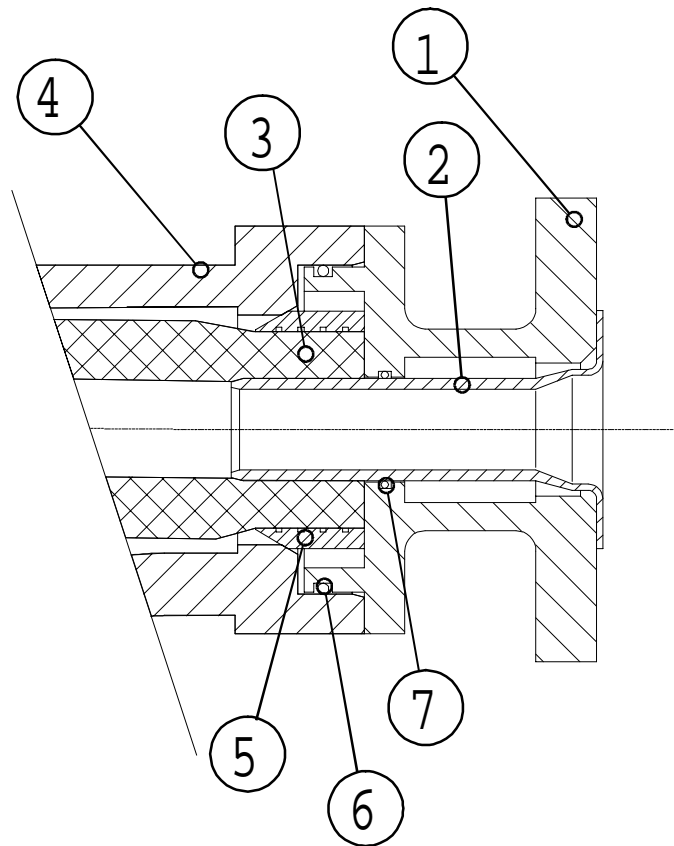

- Start the motor to remove (expel) the hose from the body.

NOTE THAT THE FRONT COVER SHOULD REMAIN INSTALLED DURING HOSE REMOVAL

INSTALLING THE HOSE - ASSEMBLY

1. Remove the cover and clean the internal surfaces of the pump body. All contamination should be removed. Lubricate the internal faces of the body of the pump where there could be friction with the hose.
2. Inspect the shoes for damage to the pressure surface that could affect performance. If the machine is being set up for the first time, see paragraph Rotor in the section CHECKS BEFORE SWITCHING ON THE PUMP.
3. Replace the front cover. (Recommended bolt torque 106 in.lbs.)
CAUTION: FRONT COVER MUST BE IN PLACE FOR PROPER HOSE INSTALLATION
4. The exterior surface of the new hose should now be cleaned and lubricated, applying manually one coat of lubricant. (PeriFlo Hoselube)
5. Install one flange (item 1) with two bolts in diagonal. After tightening these bolts, loosen them half a turn.
6. Insert the hose in the hole of the body without a flange and start the motor to feed the hose through the body of the motor. Continue until the hose just touches the preinstalled flange. Stop the motor the moment that the flange moves due to contact with the hose.
7. Remove the flange. The hose should now protrude 10 mm. from the pump body. Slide the closing ring (item 5) over the end of the hose, until the back of the closing ring aligns with the end of the hose.
8. Inspect flange O'ring (item 6) and insert O'ring (item 7), and replace as necessary.
9. Verify flange (item 1) fit insuring that the flange O'ring (item 6) is in place. The hose insert (item 2) should be pushed inside the flange (item 1), making sure that the insert O'ring (item 7) is properly aligned.
10. The mounting of the flange should now be completed carefully bolting it to the casing and assuring that the hose insert is properly positioned for insertion into the hose. Tighten the four bolts of the flange (recommended bolt torque 212 in.lbs.), making sure that the insert follows the flange, tapping towards the casing with a nylon hammer.
11. Position the other flange (as described on in step 5) and turn the motor to secure the hose in the pump. Stop the operation when the flange is moved by contact with the hose.
12. Repeat steps 7 through 10
13. Install the lower drain plug and the upper vent plug.
14. Fill the body of the pump with lubricant (PeriFlo Hoselube) to the proper level via the upper filling and inspection cover.
15. Reconnect suction/discharge piping.

PROBLEMS, CAUSES AND SOLUTIONS

PROBLEM	POSSIBLE CAUSE	SOLUCIÓN
Elevated temperature	Use of non original lubricant Low level of lubricant Elevated temperature of product Poor or bad suction conditions Excessive number of shims Excessive pumping speed	Use special lubricant PERIFLO Fill according to manufacturer's table Reduce pumping temperature Check there are no obstructions Recalculate sections and lengths Confirm the number of necessary shims Reduce velocity of pump
Reduction of capacity/pressure	Suction or discharge valve closed. Insufficient number of shims. Rupture of the hose (the product leaks to the casing) Partial obstruction of suction piping Insufficient product amount in suction reservoir Insufficient diameter of suction piping Excessive length of suction pipe High viscosity of product Entry of air via the suction connections High pulsation on suction	Open valves Confirm the number of necessary shims Replace hose Clean piping Fill reservoir Increase pipe size Reduce pump speed Shorten suction piping Reduce pump speed Reduce viscosity Increase pipe size Confirm that the pump is suitable Tighten flange joints and accessories Mount pulsation dampening equipment Reconsider application (speed etc.)
Vibrations in pump and piping	The piping is not correctly fixed together Excessive pumping speed Insufficient diameter of piping Bedplate of pump loose Elevated pulsation of pump	Refix piping Reduce the speed of the pump Increase pipe diameter Fix the bedplate firmly Install pulsation dampening equipment in the suction and/or outlet piping
Short life of the hose	Chemical attack High speed of pump High pumping temperature High working pressure Abnormal elevation of temperature Unsuitable lubricant Insufficient quantity of lubricant Cavitation of the pump	Confirm compatibility of the hose with the pumped fluid and the cleaning fluid Reduce speed of pump Reduce temperature of product Reduce speed of pump Increase diameter of piping Check number of shims Use lubricant PERIFLO Hoselube Top up lubricant Reconsider suction conditions
Stretching of the hose inside the pump	Insufficient lubricant High suction pressures (>45psi) Hose full of sediment Brackets insufficiently tightened	Top up lubricant Reduce suction pressure Clean hose Retighten brackets

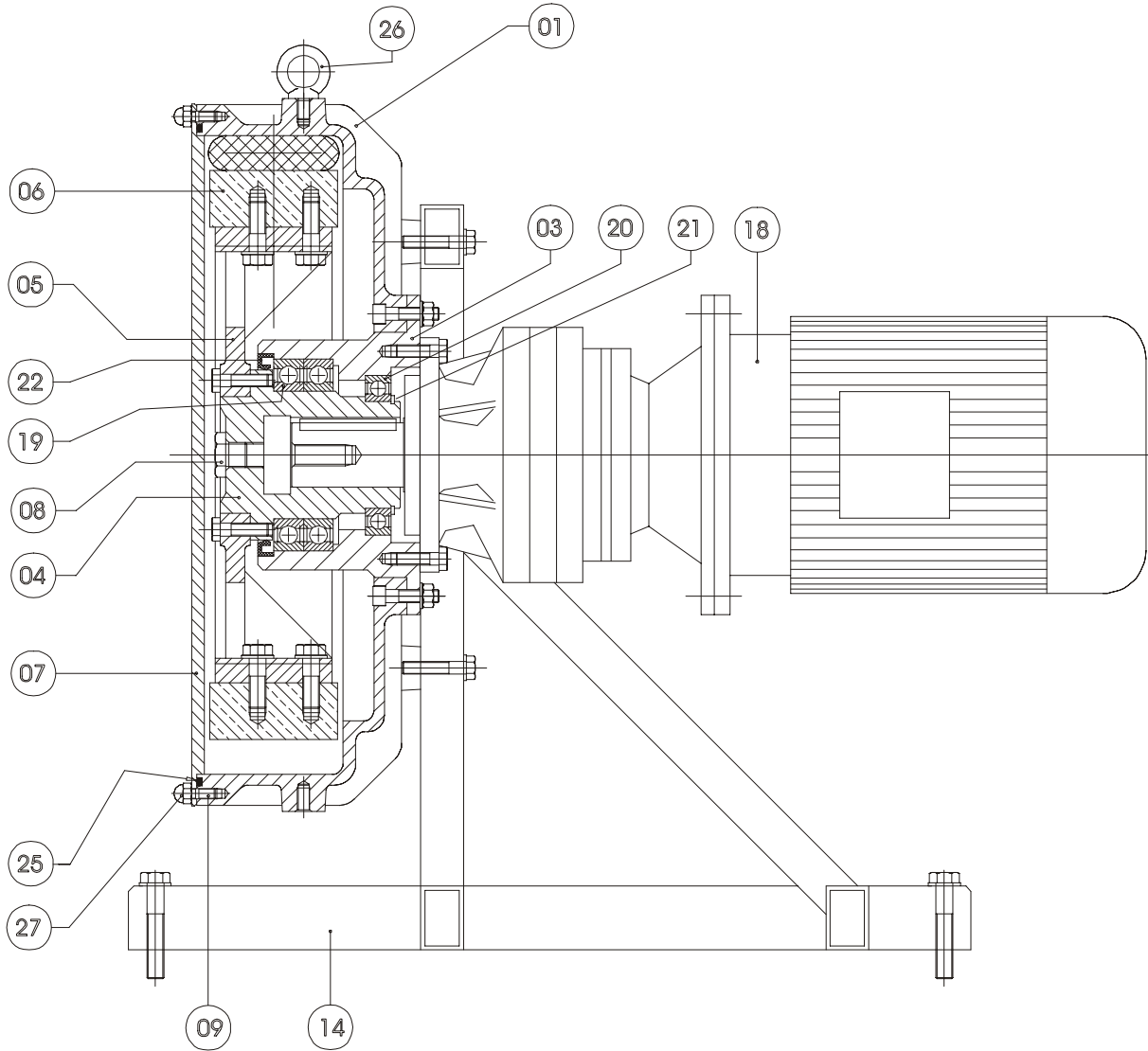

RBT-60

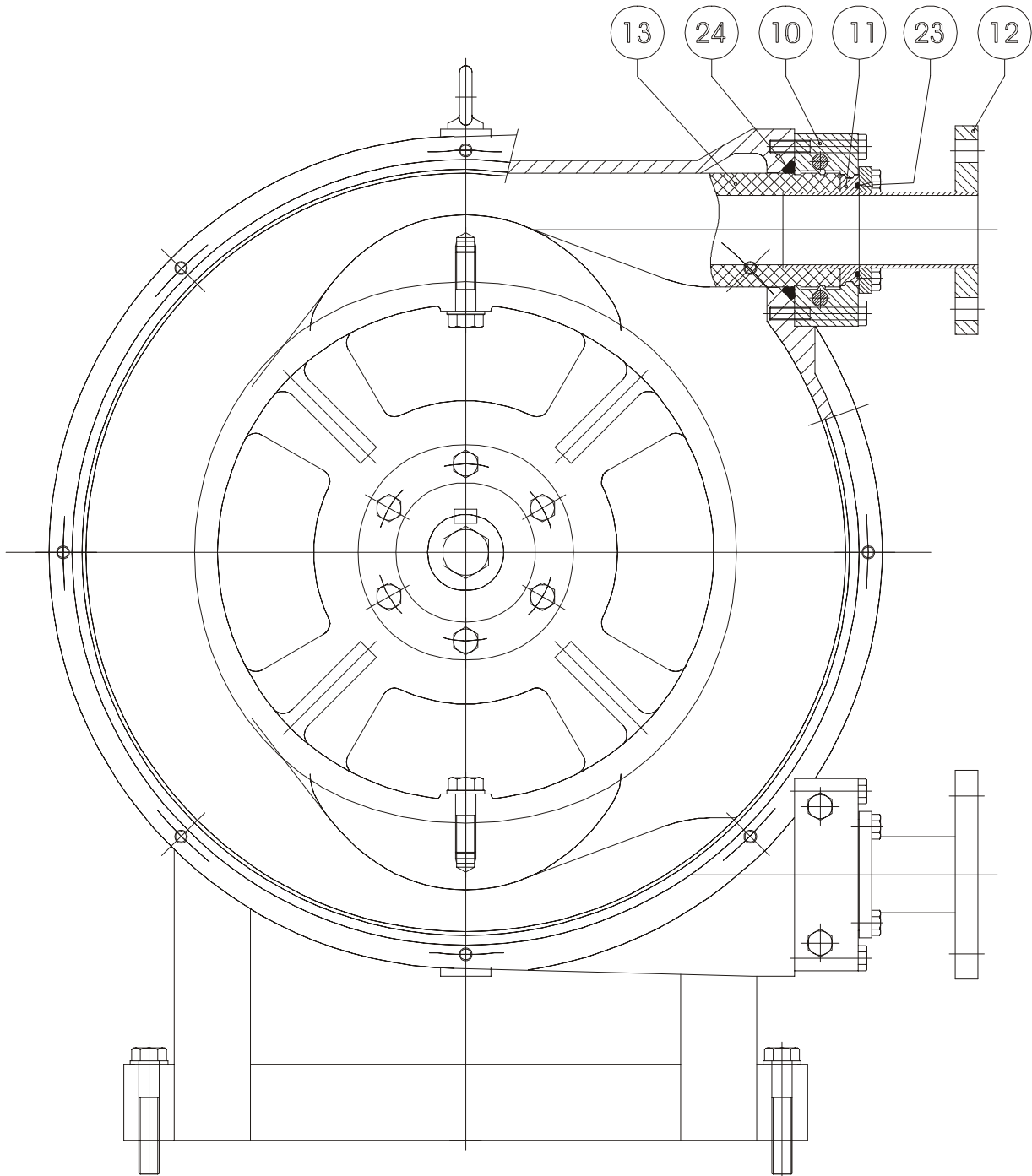

RBT-60				
Nº	DESCRIPTION	Nº	CODE	MATERIAL
1	Pump casing	1	110.00.01	Cast Iron
2	Shim		111.00.02	Stainless
3	Bearing housing	1	111.00.03	Carbon Steel
4	Rotor shaft	1	111.00.04	Carbon Steel
5	Rotor	1	111.00.05	Carbon Steel
6	Pressing shoe	2	111.00.06	Aluminum
7	Front cover	1	111.00.07	Carbon Steel
8	cap M24	1	111.00.08	
9	Stud	4	111.00.09	
10	Press flange	2	111.00.10	Anodized Steel
11	Insert (stainless)	2	111.00.11	316SS
	Insert (polypropylene)	2	111.00.35	Polypropylene
	Insert (PVDF)	2	111.00.36	PVDF
12	Connection flange ANSI	2	111.00.32	316SS
13	Natural Rubber Hose	1	111.00.18	
	Natural Rubber Hose (Food Grade)	1	111.00.19	
	Buna N Hose	1	111.00.20	
	Buna N Hose (Food Grade)	1	111.00.21	
	EPDM Hose	1	111.00.22	
14	Base - Left	1	111.00.14	Carbon Steel
15	Base - Right	1	111.00.15	Carbon Steel
16	Base Support – Middle (100mm)	1	111.00.16	Carbon Steel
17	Base Support – Middle (60mm)	1	111.00.17	Carbon Steel
18	Driver	1		
19	Front bearing	2	111.00.28	
20	Rear bearing	1	111.00.29	
21	Elastic o-ring for shaft	1	111.00.30	
22	Lip seal	1	111.00.31	
23	O-ring connection	2	111.00.23	
24	O-ring hose	2	111.00.24	
25	O-ring front cover	1	111.00.25	
26	Eye bolt	1	111.00.26	
27	Nut	4	111.00.27	
	HoseLube (5 gal)	1		

Rev 01.04.00

WARRANTY

- PeriFlo warrants it's RBT and FMP pump equipment against all defects in materials, manufacturing and workmanship for two years from the date of shipment. This warranty does not include normal wearing items such as the hose or the lubricant since their life is highly dependent on the specific operating conditions of the application and installation.

- This warranty is valid as long as the equipment functions within the parameters indicated in the technical information card supplied with every pump or on subsequent changes authorized by PERIFLO, Inc.

- This warranty includes materials and labor only, and does not include transportation of materials to or from our warehouses in Loveland, Ohio. Transportation charges will be the responsibility of the customer.