

X9

series

Process diaphragm metering pumps



X9 Process diaphragm metering pumps

X9 series OBL metering pumps, with STD innovative double diaphragm construction, are specifically designed for continuous demanding industrial applications.

Extreme reliability and durability is guaranteed by the positive return mechanism (full motion) and by the mechanically actuated replenishing valve (smart diaphragm) and built-in relief valve. These pumps are supplied as std with local visual diaphragm burst detector via pressure gauge.

On demand, pressure switch and pressure transmitter for both safe and hazardous areas can be supplied.

Oil-bathed sealess ceramic plunger guarantees low NPSH r and minimum maintenance.

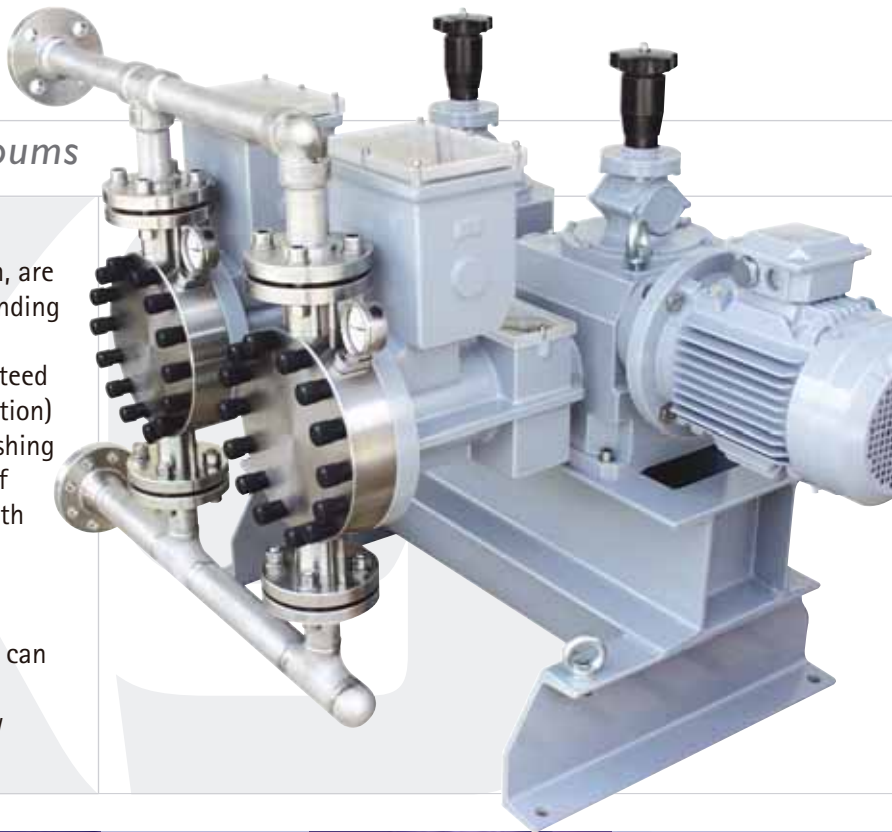

X9

API 675std

Positive return



X9 pumps, can be equipped with Z type electrical actuator, with following characteristics:

- IP 66 STD
- Manual emergency override
- Anticondensation heater (on demand)
- Non standard voltages and frequencies (on demand)

Flow rate is adjusted according to following input signals:

- 4-20 mA, 0-20 mA, 20-4 mA e 0-10 V
- Pulses (0÷2 Hz - 0÷30 Hz)
- RS 485 protocol
- PROFIBUS®



On demand X9 pumps can be supplied with pneumatic or electric actuator for remote capacity adjustment in hazardous areas.

Typical X9 applications:

- OIL&GAS
- CHEMICAL AND PETRO- CHEMICAL
- POWER STATION (boiler water & cooling water)
- FOOD INDUSTRY
- PULP&PAPER



- Modular horizontal pumps combination with different sizes and strokes per minute (each pump has its own independent internal reduction gear), for pulse-less or different injection points technical requirements.
- X9 STD pump head material include SS316L, PVC, PVDF and PTFE. Special construction with exotic materials on demand.
- X9 series conform to API 675 standard, meeting its constructional, design and performances requirements.
- X9 series compliance (94/9/CE), suitable for installation in group II, category 2 (zone 1/21) and group II category 3 (zone 2/22).



LY X9 Technical data

TYPE	FLOW RATE l/h	MAX PRESS. BAR	CONNECTIONS		kW
			THREADED	FLANGED	
LY10	1,5	100	1/4" NPT F	1/2" ANSI	0,37
LY10	8	100	1/4" NPT F	1/2" ANSI	0,37
LY15	3	100	1/4" NPT F	1/2" ANSI	0,37
LY15	23	100	1/4" NPT F	1/2" ANSI	0,37
LY20	10	70	3/8" NPT F	1/2" ANSI	0,37
LY20	33	70	3/8" NPT F	1/2" ANSI	0,37
LY25	15	60	3/8" NPT F	1/2" ANSI	0,37
LY25	50	40	3/8" NPT F	1/2" ANSI	0,37
LY30	25	40	3/8" NPT F	1/2" ANSI	0,37
LY30	100	30	3/8" NPT F	1/2" ANSI	0,37

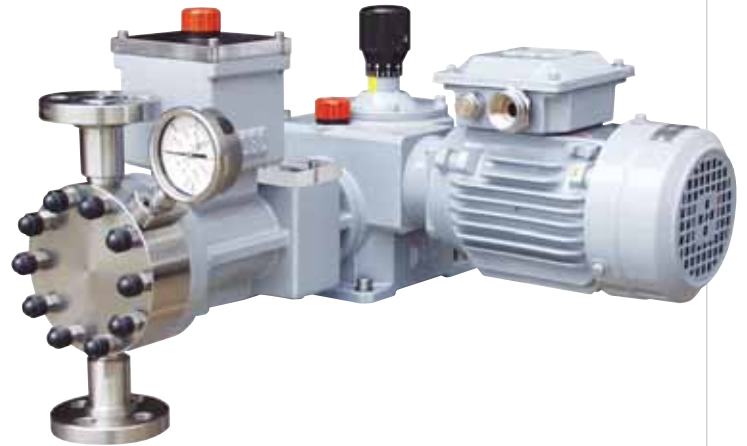

LY X9A series process diaphragm metering pump with AISI 316L pump head.



- Flow rates: • Max flow rate 100 L/h
- Motors: • kW 0,18 - kW 0,37
- Pump: • Single and multiple
- Adjustment: • Manual and automatic
- Casing material: • Cast iron
- Stroke: • 17 mm.
- Strokes/1': • 36-50-70-95-100-118
- App. Weighth: • 30÷60 Kgs

MATERIALS OF CONSTRUCTIONS

PARTS	X9 A		X9 P	
	LY 10-15	LY 20-25-30	LY 10-15	LY 20-25-30
LIQUID END	AISI 316L	AISI 316L	PVC	PVC
VALVE	CERAMIC	AISI 316L	CERAMIC	PIREX
VALVE SEAT	CERAMIC	AISI 316L	CERAMIC	PVC
VALVE GUIDE	AISI 316L	AISI 316L	PVC	PVC
VALVE SEAL	FPM	FPM	FPM	FPM
DIAPHRAGM	PTFE	PTFE	PTFE	PTFE

MAX OVERALL DIMENSIONS

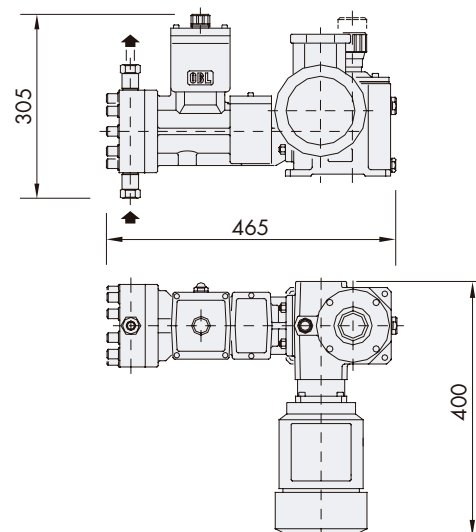

KEY TO MODEL NUMBER

LY	PUMP TYPE
30	PLUNGER Ø
X9A	SS316L VERSION
X9P	PVC VERSION
X9S	PVDF VERSION
X9T	PTFE VERSION
70	STROKES PER MINUTE
Z	ELECTRIC ACTUATOR
W	PNEUMATIC ACTUATOR
FA	ANSI FLANGED CONNECTIONS
F	DIN FLANGED CONNECTIONS

Example model number: LY 30 X9A 70 FA Z

LK X9 *Technical data*

TYPE	FLOW RATE l/h	MAX PRESS. BAR	CONNECTIONS	kW
LK30	45	70	3/4" ANSI	0,75
LK30	105	52	3/4" ANSI	0,75
LK40	80	40	3/4" ANSI	0,75
LK40	200	28	3/4" ANSI	0,75
LK50	135	25	1" ANSI	0,75
LK50	320	18	1" ANSI	0,75
LK65	230	15	1" ANSI	0,75
LK65	550	11	1" ANSI	0,75
LK80	520	10	1 1/4" ANSI	0,75
LK80	1050	5,5	1 1/4" ANSI	0,75



LK X9A series process diaphragm metering pump with AISI 316L pump head.

LK 1050 l/h

- Flow rates: • Max flow rate 1050 L/h
- Motors: • kW 0,37 - kW 0,75
- Pump: • Single and multiple
- Adjustment: • Manual and automatic
- Casing material: • Cast iron
- Stroke: • 30 mm.
- Strokes/1': • 42-60-82-100
- App. Weigth: • 40÷70 Kgs

MATERIALS OF CONSTRUCTIONS

PARTS	X9 A	X9 P
LIQUID END	AISI 316L	PVC
VALVE	AISI 316L	PIREX
VALVE SEAT	AISI 316L	PVC
VALVE GUIDE	AISI 316L	PVC
VALVE SEAL	FPM	FPM
DIAPHRAGM	PTFE	PTFE

MAX OVERALL DIMENSIONS

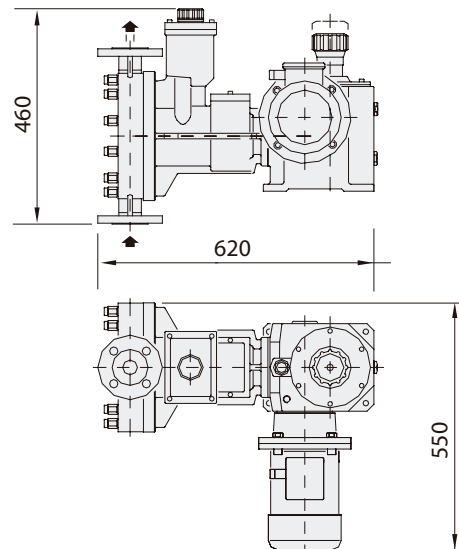

KEY TO MODEL NUMBER

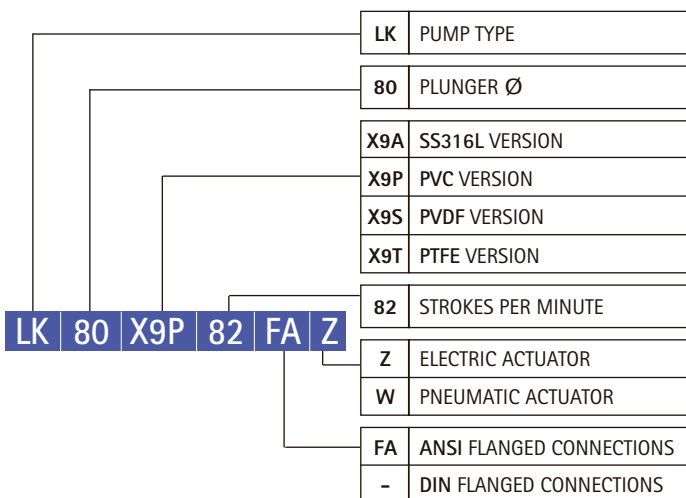

LN X9 Technical data

TYPE	FLOW RATE l/h	MAX PRESS. BAR		FLANGED CONNECTIONS	kW
		X9	X9TS		
LN25	60	100	140	3/4" ANSI	1,5-2,2
LN25	155	80	100	3/4" ANSI	1,5
LN30	112	90	-	3/4" ANSI	1,5
LN30	240	65	-	3/4" ANSI	1,5
LN65	500	22	-	1 1/2" ANSI	1,5
LN65	1050	16	-	1 1/2" ANSI	1,5
LN80	900	15	-	1 1/2" ANSI	1,5
LN80	1620	8	-	1 1/2" ANSI	1,5
LN100	1500	8	-	1 1/2" ANSI	1,5
LN100	2500	5	-	2" ANSI	1,5



LN X9A series process diaphragm metering pump with AISI 316L pump head.



- Flow rates: • Max flow rate 2500 L/h
- Motors: • kW 0,75 - kW 1,5
- Pump: • Single and multiple
- Adjustment: • Manual and automatic
- Casing material: • Cast iron
- Stroke: • 50 mm.
- Strokes/1': • 68-80-96-120
- App. Weighth: • 150 Kgs

MATERIALS OF CONSTRUCTIONS

PARTS	X9 A	X9 P
LIQUID END	AISI 316L	PVC
VALVE	AISI 316L	PIREX
VALVE SEAT	AISI 316L	PVC
VALVE GUIDE	AISI 316L	PVC
VALVE SEAL	FPM	FPM
DIAPHRAGM	PTFE	PTFE

MAX OVERALL DIMENSIONS

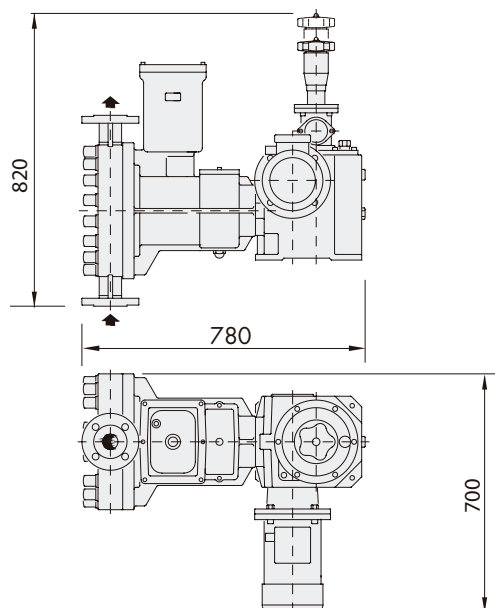

KEY TO MODEL NUMBER

LN	PUMP TYPE
100	PLUNGER Ø
X9A	SS316L VERSION
X9P	PVC VERSION
X9S	PVDF VERSION
X9T	PTFE VERSION
96	STROKES PER MINUTE
Z	ELECTRIC ACTUATOR
W	PNEUMATIC ACTUATOR
FA	ANSI FLANGED CONNECTIONS
-	DIN FLANGED CONNECTIONS

LN 100 X9A 96 FA Z

LP X9 *Technical data*

TYPE	FLOW RATE l/h	MAX PRESS. BAR		FLANGED CONNECTIONS	kW
		X9	X9TS		
LP25	55	-	260	1/2" ANSI	4
LP25	150	-	200	1/2" ANSI	4
LP30	90	-	190	3/4" ANSI	4
LP30	230	-	140	3/4" ANSI	4
LP65	500	40	-	1 1/2" ANSI	4
LP65	1050	30	-	1 1/2" ANSI	4
LP80	900	25	-	1 1/2" ANSI	4
LP80	1620	18	-	1 1/2" ANSI	4
LP100	1500	15	-	1 1/2" ANSI	4
LP100	2500	11	-	2" ANSI	4
LP120	2140	12	-	2" ANSI	4
LP120	3800	8	-	2" ANSI	4

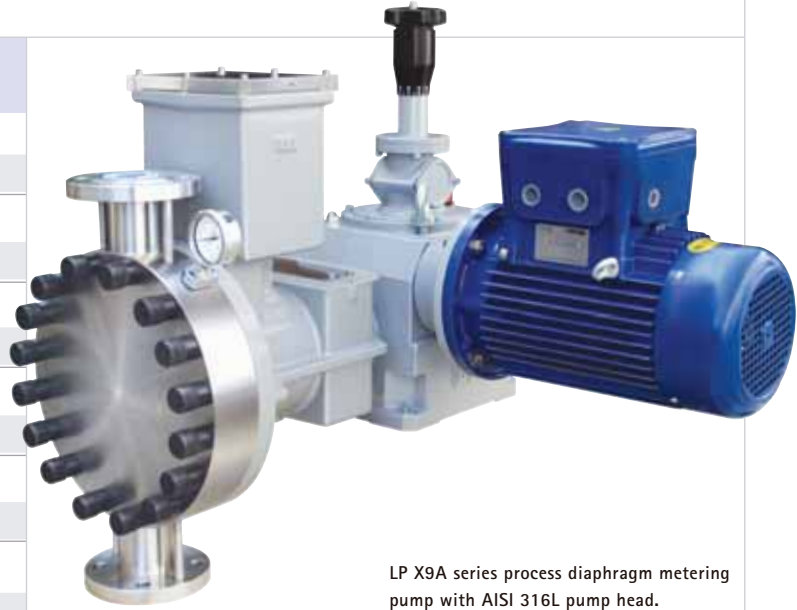

LP X9A series process diaphragm metering pump with AISI 316L pump head.

LP 3800 l/h

- Flow rates: • Max flow rate 3800 L/h
- Motors: • kW 2,2 - kW 4
- Pump: • Single and multiple
- Adjustment: • Manual and automatic
- Casing material: • Cast iron
- Stroke: • 50 mm.
- Strokes/1': • 68-82-97-120
- App. Weighth: • 170 Kgs

MATERIALS OF CONSTRUCTIONS

PARTS	X9 A	X9 P
LIQUID END	AISI 316L	PVC
VALVE	AISI 316L	PIREX
VALVE SEAT	AISI 316L	PVC
VALVE GUIDE	AISI 316L	PVC
VALVE SEAL	FPM	FPM
DIAPHRAGM	PTFE	PTFE

MAX OVERALL DIMENSIONS

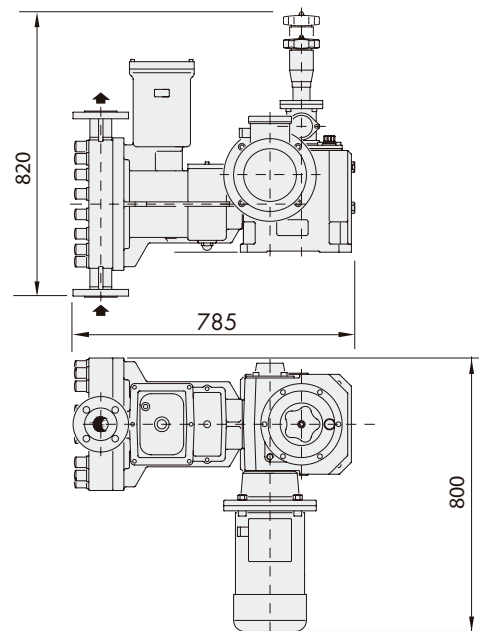

KEY TO MODEL NUMBER

LP	PUMP TYPE
120	PLUNGER Ø
X9A	SS316L VERSION
X9P	PVC VERSION
X9S	PVDF VERSION
X9T	PTFE VERSION
120	STROKES PER MINUTE
Z	ELECTRIC ACTUATOR
W	PNEUMATIC ACTUATOR
FA	ANSI FLANGED CONNECTIONS
-	DIN FLANGED CONNECTIONS

LP 120 X9A 120 FA Z



Studio_5A/F/DI_Communicazioni_Visive



KGO *Group Ltd.*

www.kgogroup.com

"The Benefit of Experience"

Specializing in:

- Pumps
- Tanks
- Mixers
- Filtration
- Systems

2198 Arbourview Drive
Oakville, Ontario L6M 3N7

Tel: 905.847.1544

Cell: 905.467.3112

Fax: 905.847.1699

garry@kgogroup.com

Technical data are subject to modifications without prior notice. - I dati tecnici possono essere modificati senza preavviso.